

Is Your Product Registered?

Contact your Dealer to verify.

Warranties are based on Registrations and reduced to 1 year without
Registration.

MARUYAMA

ILLUSTRATED PARTS LIST

MS903

PUMP

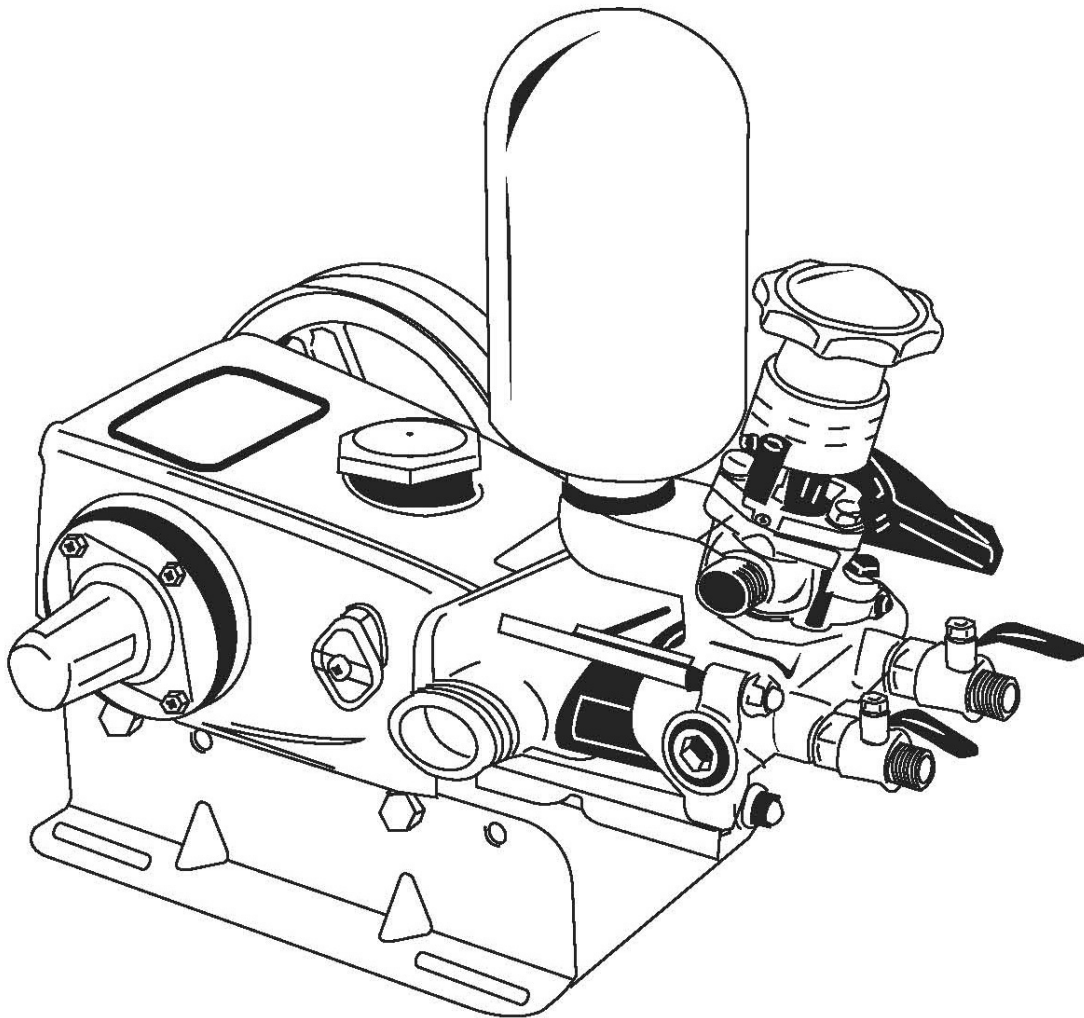

MS903
PUMP
PART #522811 06/2009



Maruyama. *E x t r a o r d i n a r y .*

1. MS903
MAIN BODY

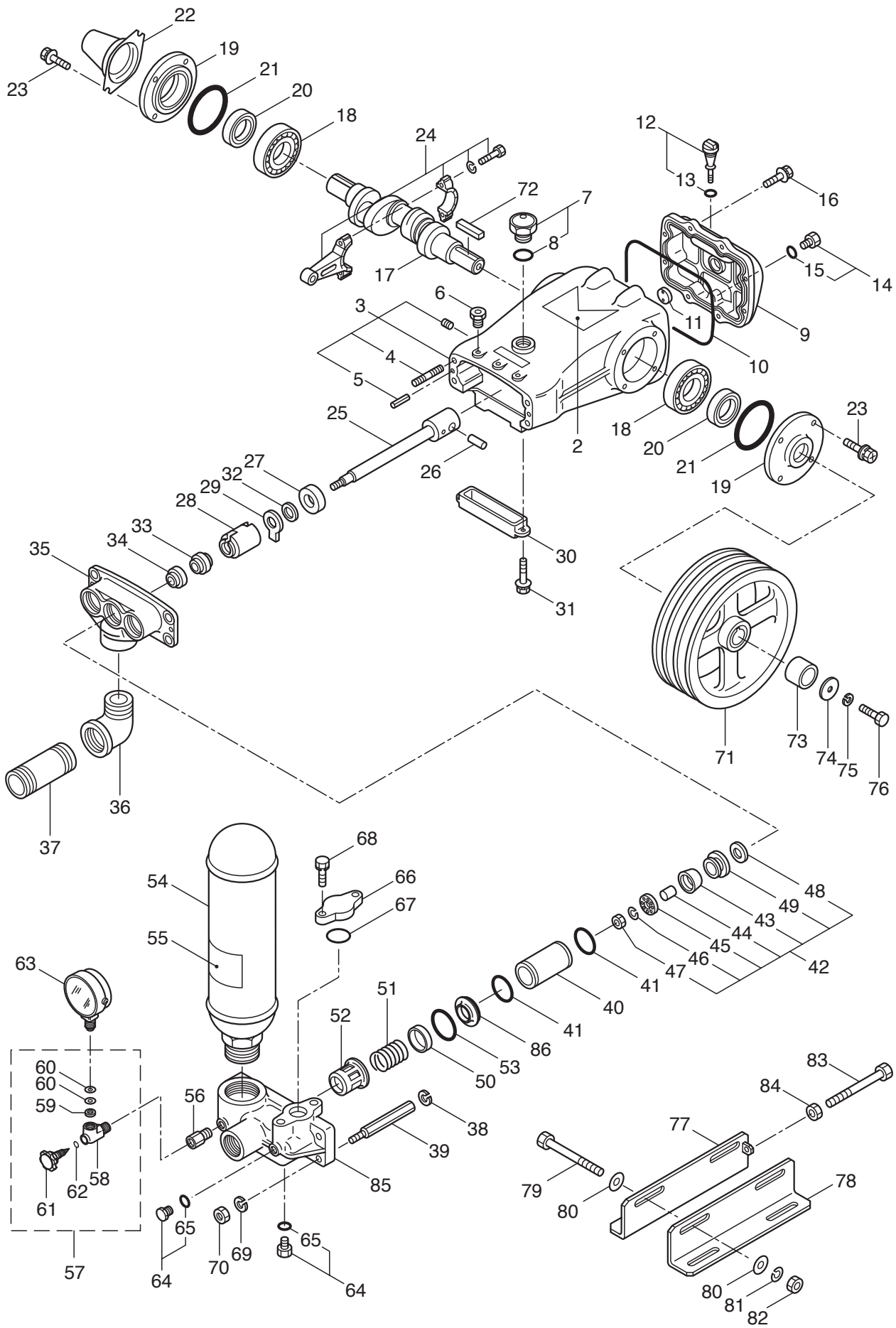

Ref. No.	Part No.	Part Name	Q'ty	Remarks
1-2	100434	Label	1	MS903
1-3	100623	Crankcase Ass'y	1	Incl.4,5
1-4	126547	Stud Bolt	4	M12X28X24X22
1-5	027488	Spring Pin	2	5X12AW
1-6	028787	Bush	3	PF1/4
1-7	091264	Oil Cap Ass'y	1	Incl.8
1-8	014177	O-Ring	1	P35
1-9	029590	Crankcase Lid	1	
1-10	027767	O-Ring	1	222X3
1-11	022289	Oil Gauge	1	30
1-12	091194	Oil Gauge Ass'y	1	Incl.13
1-13	011338	O-Ring	1	P18
1-14	091376	Plug Ass'y	1	Incl.15
1-15	023170	O-Ring	1	P12.5
1-16	126544	Bolt	8	M8X25
1-17	027846	Crankshaft	1	
1-18	026512	Bearing	2	#6308
1-19	027869	Oil Seal Case	2	
1-20	027771	Oil Seal	2	D406212
1-21	027772	O-Ring	2	G90
1-22	029004	Protector	1	
1-23	126544	Bolt	8	M8X25
1-24	048613	Connecting Rod Ass'y	3	
1-25	126660	Piston Rod	3	
1-26	027784	Piston Pin	3	14X39
1-27	027849	Oil Seal	3	S144511
1-28	027788	Seal Retainer	3	
1-29	027789	Wick(Long Tab)	3	14X40X5
1-30	027790	Oil Pan	1	
1-31	125824	Bolt	2	M6X16
1-32	120530	Packing	3	
1-33	101389	Scraper	3	
1-34	101390	Seal Packing	3	
1-35	027850	Inlet Manifold	1	
1-36	013604	Elbow	1	11/4
1-37	013619	Nipple	1	PT11/4XPF11/4
1-38	126570	Spring Washer	4	M12
1-39	027803	Bolt	4	M12X135
1-40	027844	Cylinder Pipe	3	38X47X65
1-41	025495	O-Ring	6	P41
1-42	406506	Inlet Valve Ass'y	3	Incl.43-49
1-43	028409	Piston Packing	3	39
1-44	029231	Spacer	3	8X10.5X11.5
1-45	029239	Piston Retainer	3	8X33.5XT3

1. MS903
MAIN BODY

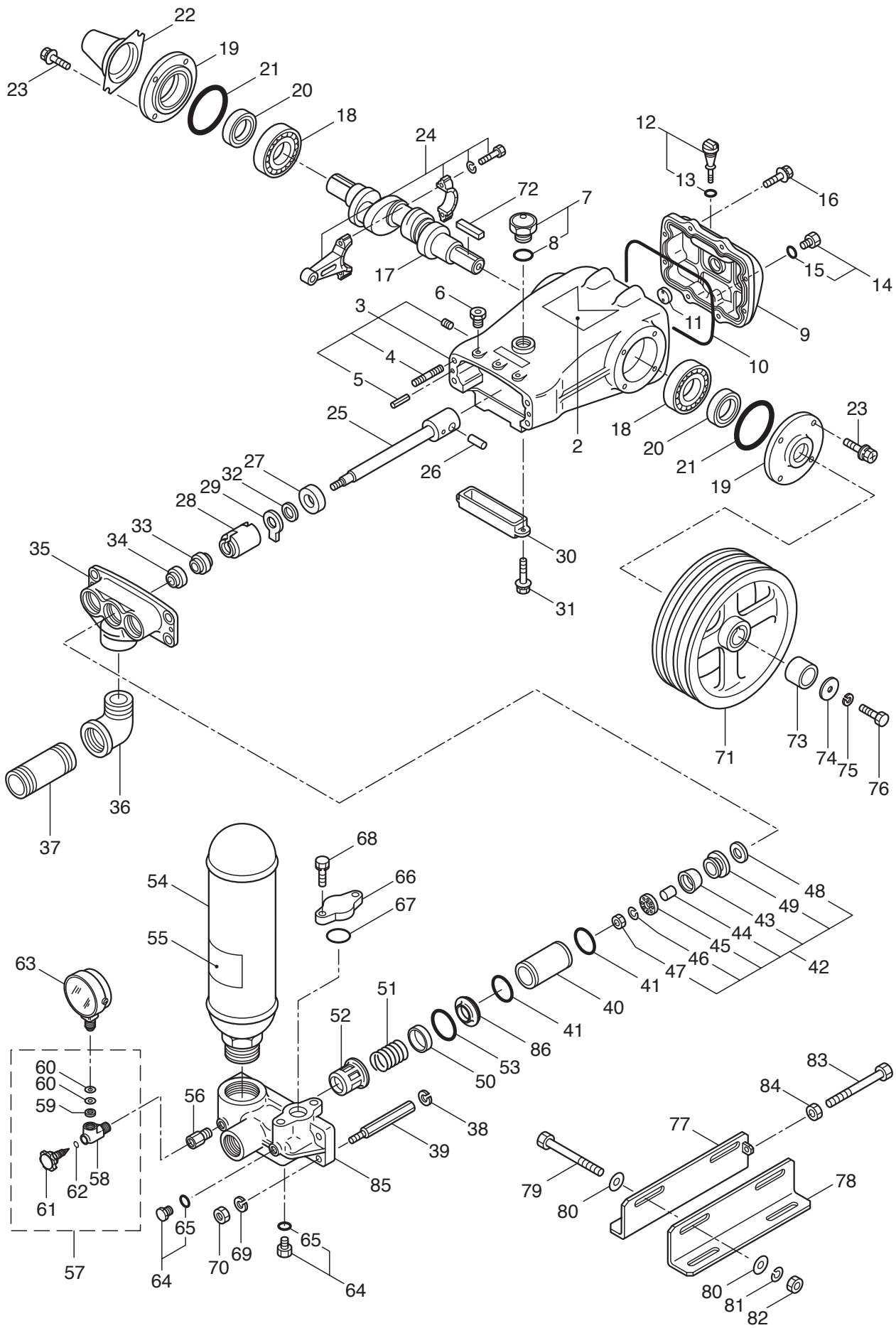

Ref. No.	Part No.	Part Name	Q'ty	Remarks
1-46	015846	Spring Washer	3	M8
1-47	117177	Nut	3	M8
1-48	029240	Inlet Valve Seat	3	
1-49	027840	Inlet Valve	3	
1-50	027952	Discharge Valve	3	
1-51	026548	Valve Spring	3	
1-52	043134	Valve Spring Retainer	3	
1-53	101392	O-Ring	3	43X2
1-54	109687	Air Chamber	1	
1-55	109048	Label	1	
1-56	109689	Bush	1	PT3/8XPT1/4
1-57	105059	Pressure Gauge Protector Ass'y	1	Incl.58-62
1-58	013642	Pressure Gauge Protector	1	PT3/8-PF1/4
1-59	011241	Packing	1	5X11XT1.5
1-60	015453	Washer	2	5X11XT0.5
1-61	027441	Needle Valve	1	
1-62	011341	O-Ring	1	3X2
1-63	121546	Pressure Gauge	1	
1-64	091376	Plug Ass'y	2	Incl.65
1-65	023170	O-Ring	2	P12.5
1-66	041503	Flange	1	
1-67	014762	O-Ring	1	P31
1-68	092530	Bolt	2	M8X25
1-69	126570	Spring Washer	4	M12
1-70	126523	Nut	4	M12
1-71	019384	V-Pulley	1	261B3
1-72	026472	Key	1	7X7X45
1-73	100115	Collar	1	30.7X42.7X38
1-74	028348	Washer	1	10.5X45XT4.5
1-75	126231	Spring Washer	1	M10
1-76	088146	Bolt	1	M10X1.25X25
1-77	027774	Rail A	1	
1-78	027775	Rail B	1	
1-79	126534	Bolt	2	M12X160X50
1-80	126575	Washer	4	M12
1-81	126570	Spring Washer	2	M12
1-82	126523	Nut	2	M12
1-83	080372	Bolt	2	M10X80
1-84	126522	Nut	2	M10
1-85	027851	Discharge Manifold	1	
1-86	101391	Valve Seat	3	

2. MS903
ACCESSORIES

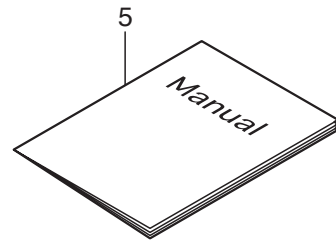
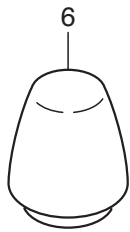

Ref. No.	Part No.	Part Name	Q'ty	Remarks
2-1	011341	O-Ring	2	3X2
2-2	025495	O-Ring	3	P41
2-3	103687	Packing	2	23.5X30XT2
2-4	023336	Packing	2	31X39XT2
2-5	090107	Instruction Manual	1	
2-6	027853	Tool	1	



Maruyama U.S., Inc.
3570 Shelby Lane
Denton, TX 76207
940-383-7400 voice
940-383-7466 fax

www.maruyama-us.com