

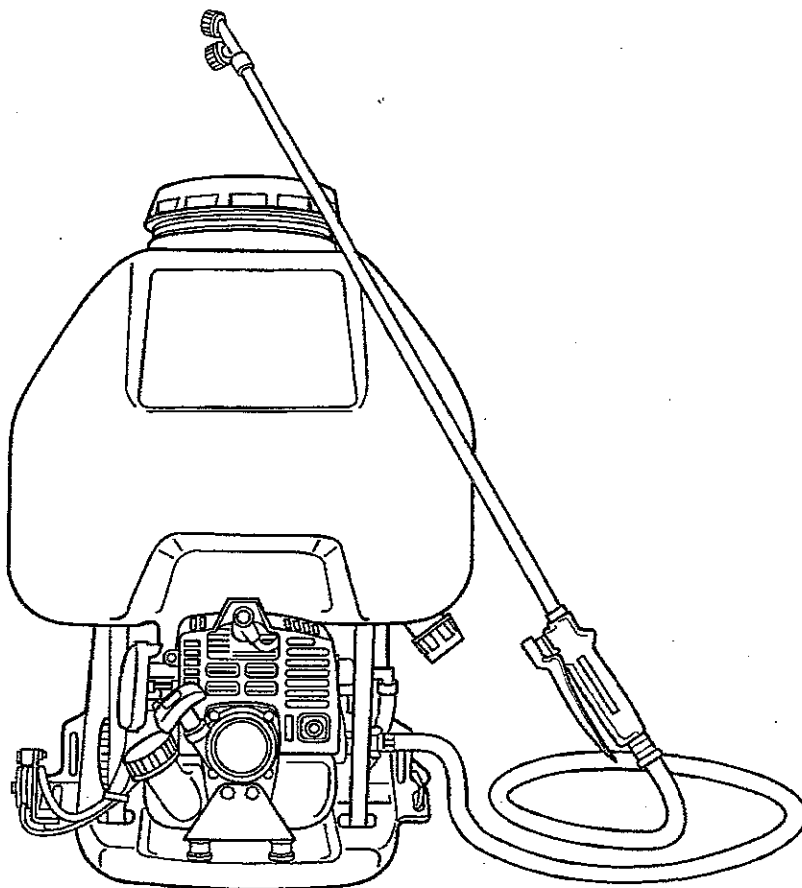

**BACKPACK POWER SPRAYER
MS068**



Owner's/Operator's Manual

Completely read and understand this manual before using this product.



Limited Warranty Statement

All Maruyama products are warranted to the original purchaser to be free from defects in material and workmanship **from the date of purchase** for the time periods listed as follows:

Lifetime for inner drive shafts on trimmers and brushcutters and all ignition modules. **3 years** for residential, non-institutional, non-income producing use. **1 year** for industrial, commercial, institutional, rental and income producing use. **Engine, refer to engine manufacturer's warranty statement. Maruyama engines are covered by this limited warranty statement.**

Any part of a Maruyama product found to be defective within the applicable warranty period shall, at Maruyama's option, be repaired or replaced without charge. Warranty consideration is obtained by delivering any Maruyama product believed to be defective to an Authorized Maruyama Servicing Dealer within the applicable warranty period.

The purchaser shall not be charged for diagnostic labor that leads to the determination that a warranted part is defective, if the diagnostic work is performed at a Maruyama Dealer.

Any warranted part which is not scheduled for replacement as required maintenance, or which is scheduled only for regular inspection to the effect of "repair or replace as necessary" shall be warranted for the warranty period. Any warranted part which is scheduled for replacement as required maintenance shall be warranted for the period of time up to the first scheduled replacement point for that part. Maruyama Mfg. Co., Inc. is liable for damages to other engine components caused by the failure of warranted part still under warranty.

The purchaser is responsible for the performance of the required maintenance, as defined by Maruyama Mfg. Co., Inc. in the Owner's/Operator's Manual.

EMISSION-RELATED PARTS WARRANTY: In addition to the above warranty coverage, Maruyama Mfg. Co., Inc. will repair or replace, free of charge, for the original purchaser and each subsequent purchaser any emission-related part or parts found to be defective in material and workmanship for two (2) years from original retail delivery date. **Emission-related parts are the carburetor assembly, the ignition coil assembly, the ignition rotor and the spark plug.** Any replacement part that is equivalent in performance and durability may be used in non-warranty maintenance or repairs, and shall not reduce the warranty obligations of Maruyama Mfg. Co., Inc.

This warranty does not cover the following:

1. Maintenance items (excluding defects in materials and workmanship) including hoses, spark plugs, starter rope, air and fuel filters, clutch shoes, vibration isolators, throttle cables and all cutting attachments, etc.
2. Extra expenses including shipping and handling, travel, payment for lost time or pay and for any inconvenience and storage.
3. Alterations or modifications including aftermarket parts not authorized by Maruyama U.S., Inc.
4. Wear, accident, abuse, neglect, misuse, negligence, improper fuels, lubricants, fuel mixtures (when applicable), or failure to operate or maintain the product in accordance with instructions approved by Maruyama.

Repair or replacement as provided under this warranty is the exclusive remedy of the consumer. Maruyama shall not be liable for any incidental or consequential damages for breach of any express or implied warranty on these products except to the extent prohibited by applicable law. Any implied warranty of merchantability or fitness for a particular purpose on these products is limited in duration to the warranty period as defined in the limited warranty statement. Maruyama reserves the right to change or improve the design of the product without notice and does not assume obligation to update previously manufactured products.

This warranty provides you with specific legal rights which may vary from state to state.

It is the Owner's and Dealer's responsibility to make sure the Warranty Registration Card is properly filled out and mailed to Maruyama U.S., Inc. Proof of purchase and registration will be required in order to obtain warranty service.

To locate an Authorized Maruyama Servicing Dealer nearest you, contact Maruyama U.S., Inc. at **1-253-735-7368**.

Maruyama U.S., Inc.

PO Box 309

Auburn, WA 98071-0309

Effective March 1, 1997

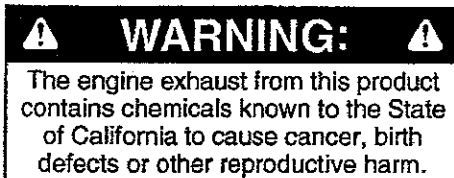

FEDERAL AND CALIFORNIA EMISSION CONTROL WARRANTY STATEMENT YOUR WARRANTY RIGHTS AND OBLIGATIONS

The U.S. Environmental Protection Agency (EPA), the California Air Resources Board (CARB), and Maruyama Manufacturing Company, Inc. are pleased to explain the emission control system warranty on your utility/lawn/garden equipment engine. In California, new 1995 and later utility/lawn/garden equipment engines must be designed, built and equipped to meet the State's stringent anti-smog standards. In other states, new 1997 and later model year utility/lawn/garden equipment engines must be designed, built and equipped, at the time of sale, to meet the U.S. EPA regulations for small nonroad engines. The equipment engine must be free from defects in materials and workmanship which cause it to fail to conform with U.S. EPA standards for the first two years of engine use from the date of sale to the ultimate purchaser. Maruyama Manufacturing Company, Inc. must warrant the emission control system on your utility/lawn/garden equipment engine for the period of time listed above provided there has been no abuse, neglect or improper maintenance of your utility/lawn/garden equipment engine.

Your emission control system may include parts such as the carburetor or fuel injection system, the ignition system, and catalytic converter. Also included may be hoses, belts, and connectors and other emission related assemblies.

Where a warrantable condition exists, Maruyama Manufacturing Company, Inc. will repair your utility/lawn/garden equipment engine at no cost to you, including diagnosis (if the diagnostic work is performed at an authorized dealer), parts, and labor.

MANUFACTURER'S WARRANTY COVERAGE:

The 1995 and later utility/lawn/garden equipment engines are warranted for two years in California. In other states, 1997 and later model year utility/lawn/garden equipment engines are also warranted for two years. If any emission-related part on your engine is defective, the part will be repaired or replaced by Maruyama Manufacturing Company, Inc. free of charge.

OWNER'S WARRANTY RESPONSIBILITIES:

(a) As the utility/lawn/garden equipment engine owner, you are responsible for the performance of the **required maintenance listed in your owner's manual.**

Maruyama Manufacturing Company, Inc. recommends that you retain all receipts covering maintenance on your utility/lawn/garden equipment engine, but Maruyama Manufacturing Company, Inc. cannot deny warranty solely for the lack of receipts or for your failure to ensure the performance of all scheduled maintenance. Any replacement part or service that is equivalent in performance and durability may be used in non-warranty maintenance or repairs, and shall not reduce the warranty obligations of the engine manufacturer.

- (b) As the utility/lawn/garden equipment engine owner, you should be aware, however, that Maruyama Manufacturing Company may deny you warranty coverage if your utility/lawn/garden equipment engine or a part has failed due to abuse, neglect, improper maintenance or unapproved modifications.
- (c) You are responsible for presenting your utility/lawn/garden equipment engine to a Maruyama Manufacturing Company, Inc. service center as soon as a problem exists. The warranty repairs should be completed in a reasonable amount of time, not to exceed **30 days**.

If you have any questions regarding your warranty rights and responsibilities, you should contact Maruyama U.S., Inc. at **1-425-885-0811**.

COVERAGE

Maruyama Manufacturing Company, Inc. warrants to the ultimate purchaser and each subsequent purchaser that your utility/lawn/garden equipment engine will be designed, built and equipped, at the time of sale, to meet all applicable regulations. Maruyama Manufacturing Company, Inc. also warrants to the initial purchaser and each subsequent purchaser that your utility/lawn/garden engine is free from defects in materials and workmanship which cause the engine to fail to conform with applicable regulations for a period of two years.

The 1995 and later utility/lawn/garden equipment engines are warranted for two years in California. In all other states for 1997 and later model years, EPA requires manufacturers to warrant utility/lawn/garden equipment engines for two years. These warranty periods will begin on the date the utility/lawn/garden equipment engine is purchased by the initial purchaser. If any emission-related part on your engine is defective, the part will be replaced by Maruyama Manufacturing Company, Inc. at no cost to the owner.

Maruyama Manufacturing Company, Inc. shall remedy warranty defects at any authorized Maruyama Manufacturing Company, Inc. engine dealer or warranty station. Any authorized work done at an authorized dealer or warranty station shall be free of charge to the owner if such work determines that a warranted part is defective. Any manufacturer-approved or equivalent replacement part may be used for any warranty maintenance or repairs on emission-related parts, and must be provided free of charge to the owner if the part is still under warranty, Maruyama Manufacturing Company, Inc. is liable for damages to other engine components caused by the failure of a warranted part still under warranty.

The California Air Resources Board's Emission Warranty Parts List specifically defines the emission-related warranted parts, (EPA's regulations do not include a parts list, but EPA considers emission-related warranted parts to include all the parts listed below.) These warranted parts are: **the carburetor assembly, the ignition coil assembly, the ignition rotor and the spark plug.**

MAINTENANCE REQUIREMENTS

The owner is responsible for the performance of the required maintenance as defined by the Maruyama Manufacturing Company, Inc. in the owner's manual.

LIMITATIONS

This Emission Control System Warranty shall not cover any of the following:

- (a) repair or replacement required because of misuse or neglect, lack of required maintenance, repairs improperly performed or replacements not conforming to Maruyama Manufacturing Company, Inc. specifications that adversely affect performance and/or durability, and alterations or modifications not recommended or approved in writing by Maruyama Manufacturing Company, Inc., and
- (b) replacement of parts and other services and adjustments necessary for required maintenance at and after the first scheduled replacement point.

Names of components

Accessories

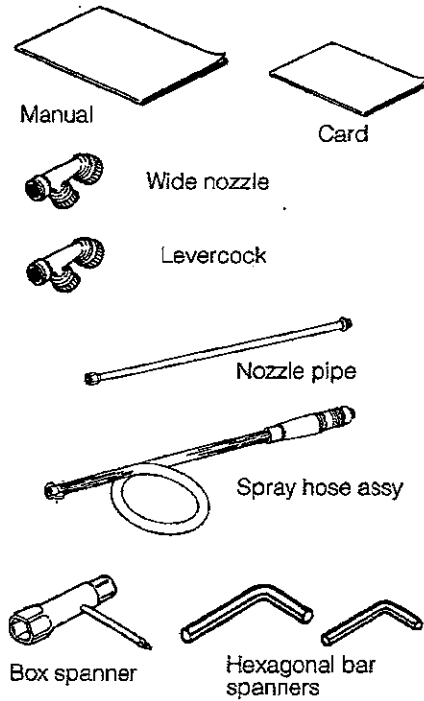
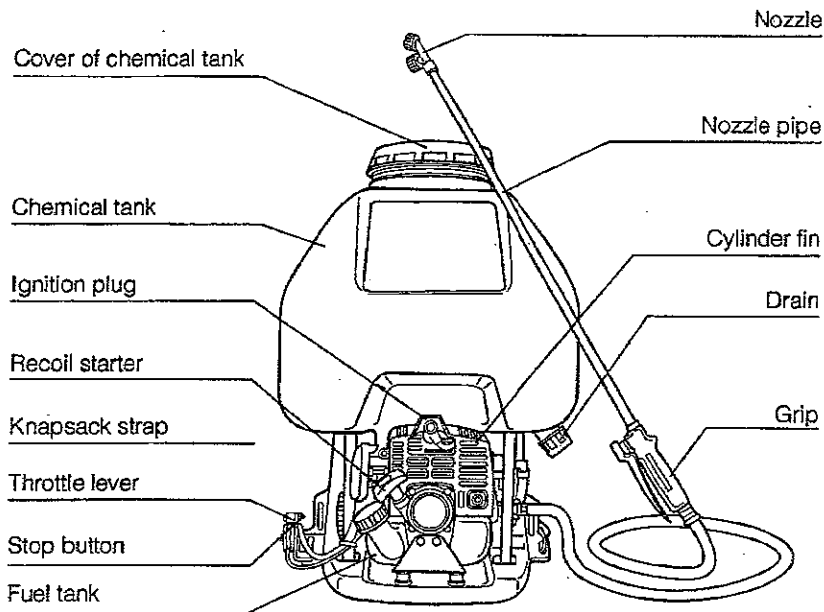

Assembling

Attach the wide nozzle, the nozzle pipe, the lever cock in that order to the spray hose, and connect the other end of the hose to the spray outlet.

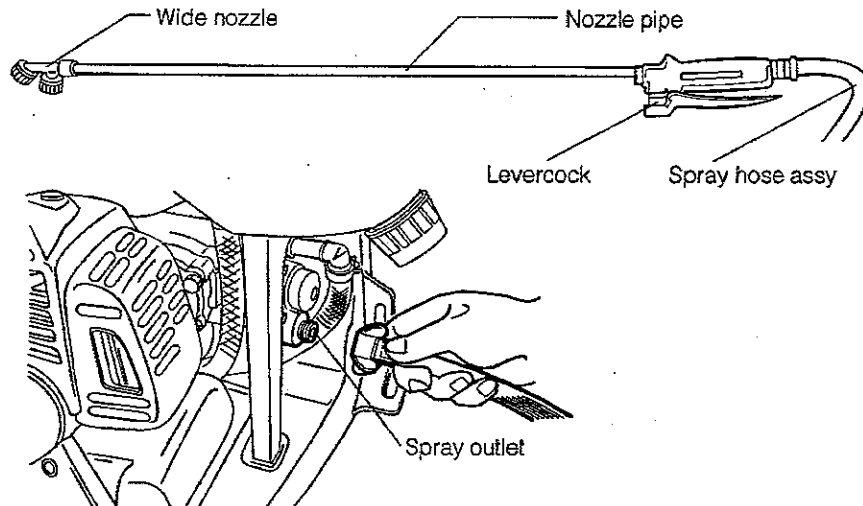

Pre-operation preparation

Oiling

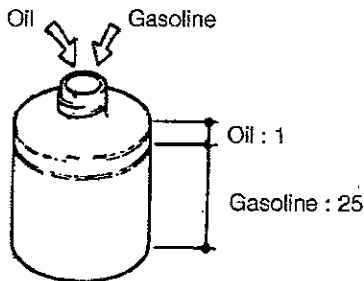

Be sure to use 2 cycle exclusive oil.

Be sure of the engine stopped and cool.

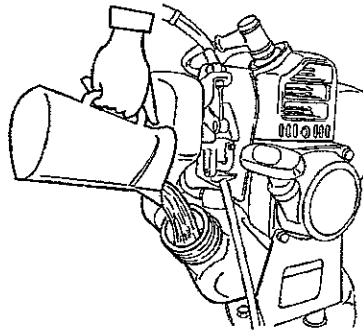

Neither overfill nor spill the fuel on to the engine.

Dilution of Chemicals / Charging to the chemical tank

Caution: Agricultural chemicals are extremely dangerous, and must be handled with care. Read the manual for specific chemical carefully before use.

Dissolve water dispersible powder in a separate container before filling. Be sure not to get foreign material into the chemicals.

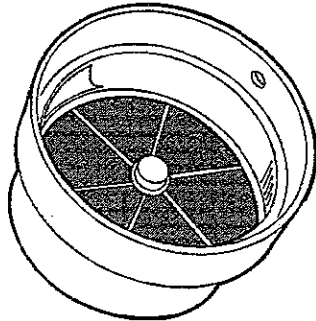

Always fill the chemical tank through the strainer so that contaminants are not mixed into the chemicals.

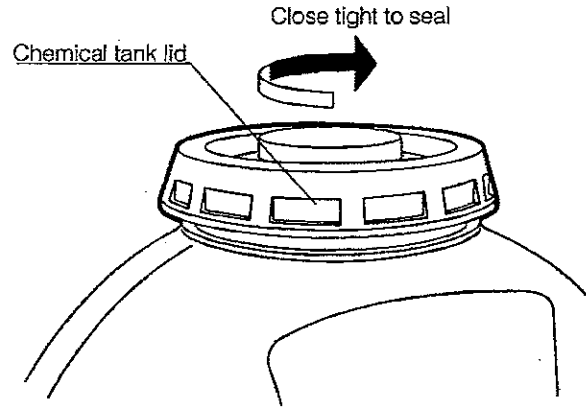

Open the nozzle, and bleed until the chemical is draining out, and then close the nozzle securely. Before spraying the agrochemical, be sure to put on suitable protective clothing to protect yourself against contact with and breathing it. Observe the following cautions for safe operation:

- Be sure to close the chemical tank cover securely.
- Check the spray hose and nozzle connections to make sure there are no leaks.
- Always stop the engine before refilling the fuel tank or changing the nozzle.
- When carrying a full chemical tank, be careful not to lose your balance.

Starting the engine

Important: When starting the engine, be sure to fill the chemical tank with pure water or chemical liquid. Never run the engine when the chemical tank is empty.

Pump the primer bulb until fuel can be seen flowing through the fuel return line, and pull the choke lever to full close. (During hot weather and when the engine is already warmed up, the choke lever may be set to full open.)

Set the throttle lever to the middle speed position (not necessarily to maximum).

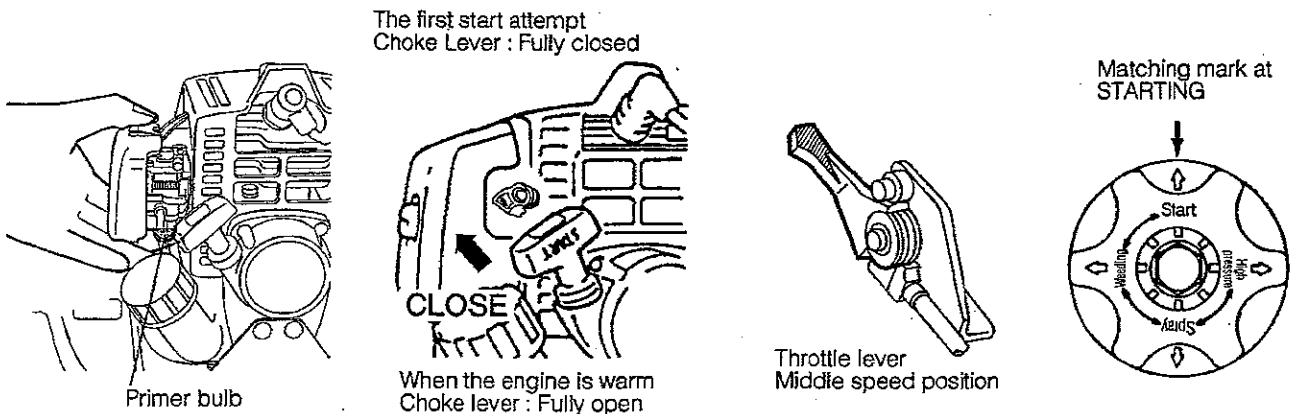

Pull the recoil starter lightly 2 - 3 times.

Pull the recoil starter strongly to start the engine.

If the engine stops after a few revolutions, set the choke to open, and pull the recoil starter rope strongly again to restart it. **Note:** If the engine does not catch even after the starter is pulled several times, set the choke lever to full open and pull the starter rope. Be sure not to pull the starter lever completely out. After the engine starts, open the choke lever slowly, move the throttle lever to the low-speed side, and let the sprayer warm up for 2 - 3 minutes.

Pull briskly

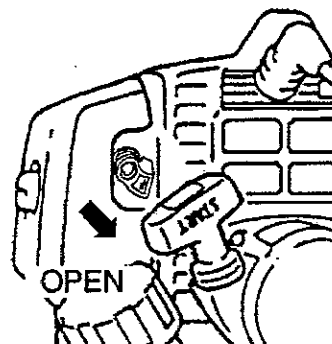
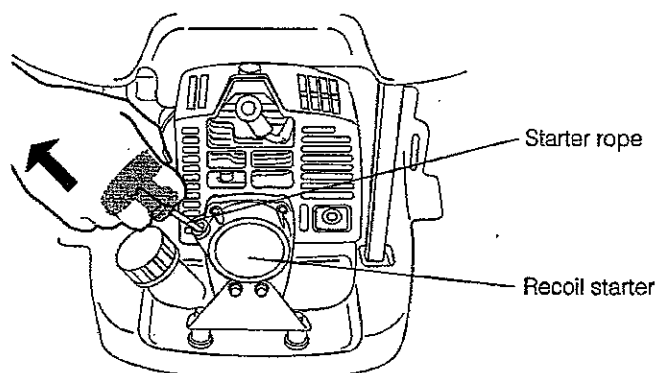

Operation

1. When the engine starts and pump is suctioning

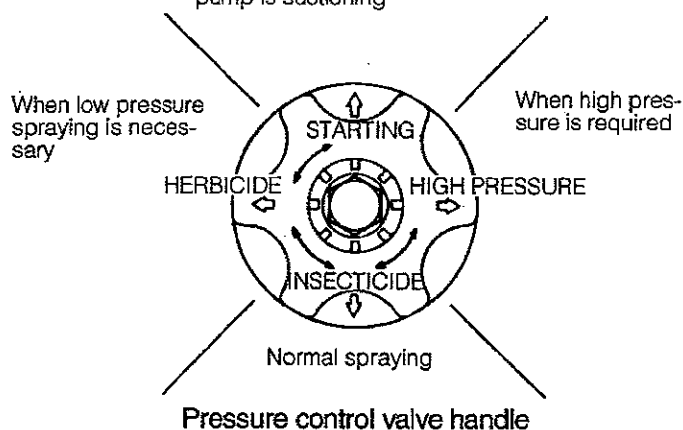

2. High speed running

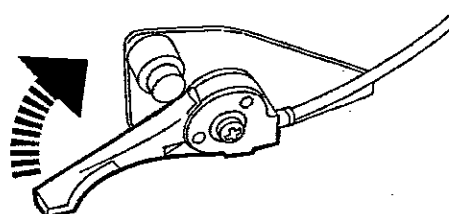

1. Turn the handle of the control valve, and set it to the position for HERBICIDE, INSECTICIDE or HIGH PRESSURE to match the pressure to operating conditions.

2. Check spraying conditions and the status of the equipment, then shoulder the equipment and set the throttle lever to the high speed position.
3. When the nozzle cock is opened, chemicals will be atomized as they come out of the nozzle.

[IMPORTANT]

When the pressure control valve handle is changed to INSECTICIDE or HERBICIDE, with the throttle being fully open at HIGH PRESSURE position of pressure control valve handle, the engine speed will become too high, corresponding to the extent of lowered pressure. Therefore, use the equipment with the throttle lever somewhat turned back from the fully opened condition, when the equipment is used at the position for INSECTICIDE or HERBICIDE.

Be careful of the amount of fuel in the fuel tank, and refill it when it becomes low.

Stop

Temporary halt during operation

- Close the nozzle, and return the throttle lever to low speed.
- Press the engine stop button.
- After the engine stops, set the sprayer down.

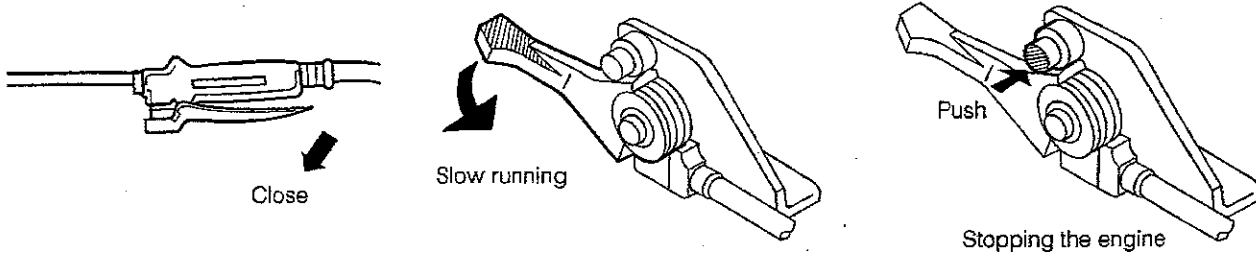

Stopping the sprayer after completing spraying

- Remove the chemical tank drain cap, and drain off all of the chemical.
- Fill the chemical tank with clean water, operate the engine, and clean the pump and hose interior by spraying the clean water. Drain off remaining water through the drain.

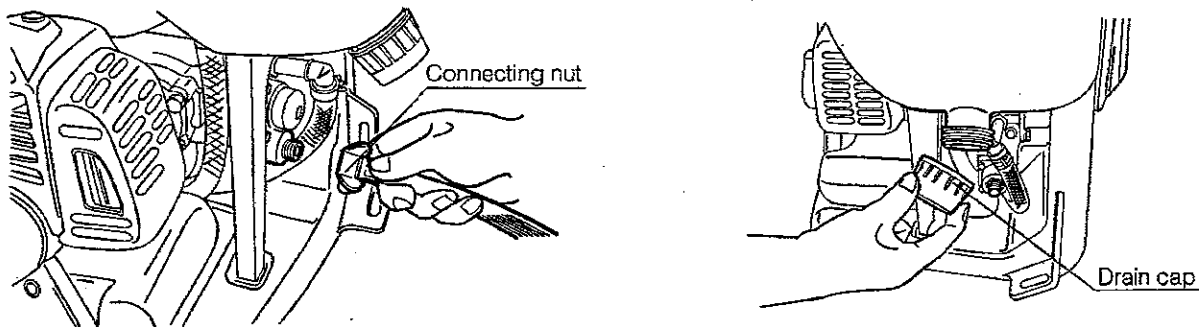

Start the engine at just less than high speed for 15 - 20 seconds to spray out the water in the spray hose and nozzle. When water stops coming from the nozzle, turn off the engine at once.

Maintenance

Cleaning the air cleaner

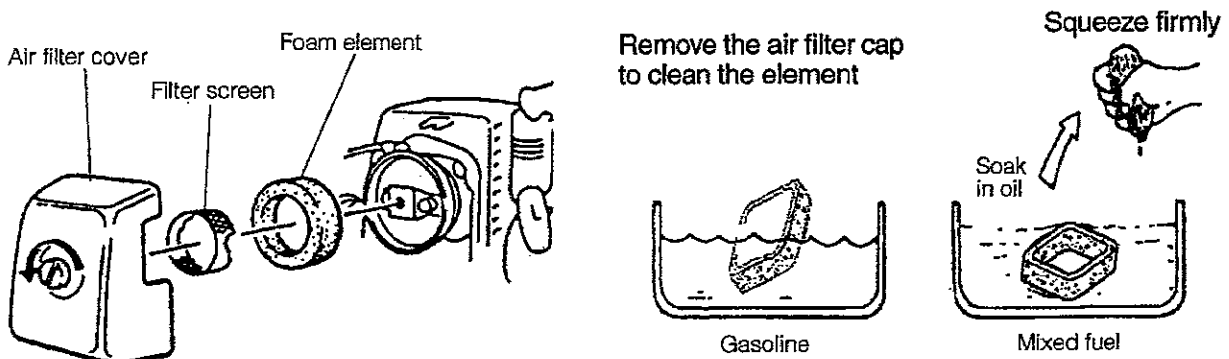

Plug

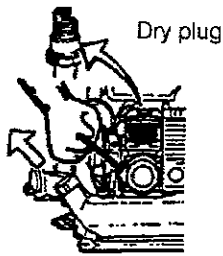

Pull 2 - 3 times

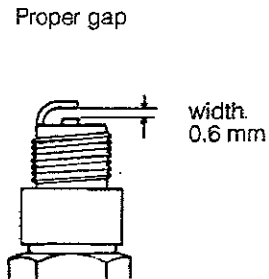
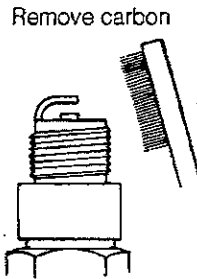

Storage

After using the sprayer for the season, store it until the next season of use as follows:

- a) Drain off all fuel from the fuel tank and the carburetor.
- b) Remove the spark plug and coat the interior of the cylinder with a small amount of oil. Pull the recoil starter lightly 2 - 3 times to spread the oil over the cylinder completely.

1. Remove the plug.

2. Apply a few drops of oil.



3. Pull 2 or 3 times.

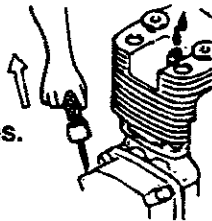

4. Connect the plug.

- c) Pull the recoil starter out slightly and stop it in place where you feel resistance start (compression starts).
- d) Clean the entire sprayer completely, cover it so it does not accumulate dirt and dust, and store it in a dry, cool location.

Trouble-shooting : Pump

Trouble	Cause	Countermeasure
No suction	Looseness in the hose.	Tight securely.
	Suction hose is clogged with chemicals.	Disassemble and clean.
	Worn piston packing.	Replace with new one.
	Foreign object in valve parts.	Disassemble and clean.
Poor spray quality	Worn piston packing.	Replace with new one.
	Flaw on cylinder inside surface.	Replace with new one.
	Flaw on exhaust valve.	Replace with new one.
	Worn pressure control valve seat.	Replace with new one.
	Worn pressure control valve handle.	Replace with new one.
	Foreign object in valve parts.	Disassemble and clean.
	Worn nozzle hole.	Replace with new one.
	Too many nozzles attached.	Reduce number of nozzles or replace with nozzle of smaller holes.

When engine fails to start:

	Diagnoses	Causes
There is fuel, but spark plug fails to ignite fuel mix.	There is power at the terminal.	Drawing too much fuel. Faulty spark plug gap. Faulty spark plug insulation.
	No power at the terminal.	Faulty Ignition coil unit or broken wire. A break or short in the ignition coil.
There is fuel and spark plug is functioning.	Compression is good.	Bad mixture.
	Compression is bad.	Faulty packing or tightening. Spark plugs not tightened properly. Piston rings are sticking.
No fuel in the carburetor		No fuel in the tank. Fuel tank air vent is plugged. Lines are bent.

Engine fails to run smooth:

	Diagnoses	Causes
No power	Compression is good and there is no miss fire.	Air cleaner element is plugged up. Air has entered fuel line joints. Faulty choke lever Carbon build-up on cylinder muffler.
	Compression is bad, and there is miss fire.	Burnt spark plugs. Short in cable. Bad mixture of piston ring wear. Marks on cylinder, cracks in the piston head.
Engine overheated		Fuel is too low (mixture is too thin) Faulty mixture, not enough mixture. Carbon piled up, overloaded operation. Faulty spark plug Plugged cylinder or coolant fines.
Inaccurate explosion		Carburetor not adjusted properly Faulty spark plug Faulty magneto or internal short
Engine doesn't sound right		Overheated cylinders Overload operation Faulty mixture or incorrect ratio Internal engine damage
Slow acceleration		Carburetor not adjusted properly or faulty compression. Poor gasoline oil quality Carbon pile-up

Specification

Dimension	
Height x Width x Length (<i>mm</i>)	25.0 in. x 18.3 in. x 14.6 in (<i>635 x 465 x 365</i>)
Dry weight (<i>kg</i>)	18.9 lbs (<i>8.6</i>)
Chemical tank capacity (<i>liter</i>)	6.6 gal (<i>25</i>)
Fuel tank capacity (<i>liter</i>)	.47 qts (<i>.5</i>)
Pump	
Type	Maruyama twin uni-flow
Maximum pressure (<i>kgf/cm²</i>)	360 PSI (<i>2.5</i>)
Suction (<i>liter/min</i>)	1.6 GPM (<i>6.1</i>)
Rotational frequency (<i>rpm</i>)	1800 rpm
Engine	
Model	MARUYAMA AE230
Type	Forced Air Cool, 2-cycle
Displacement	23 cc
Rated continuous output	0.65/6500 PS/rpm
Fuel	Mixed gasoline (25 : 1)
Ignition system	Electronic ignition
Spark plug	NGK BPM6Y
Starting system	Recoil starter

The specification may be changed for product improvement, without prior notice.



P/N 119828-01
98.04 TAP