

MARUYAMA

OPERATOR'S MANUAL

Water Pump

MP2531CE-1

MP2531CE-1CA

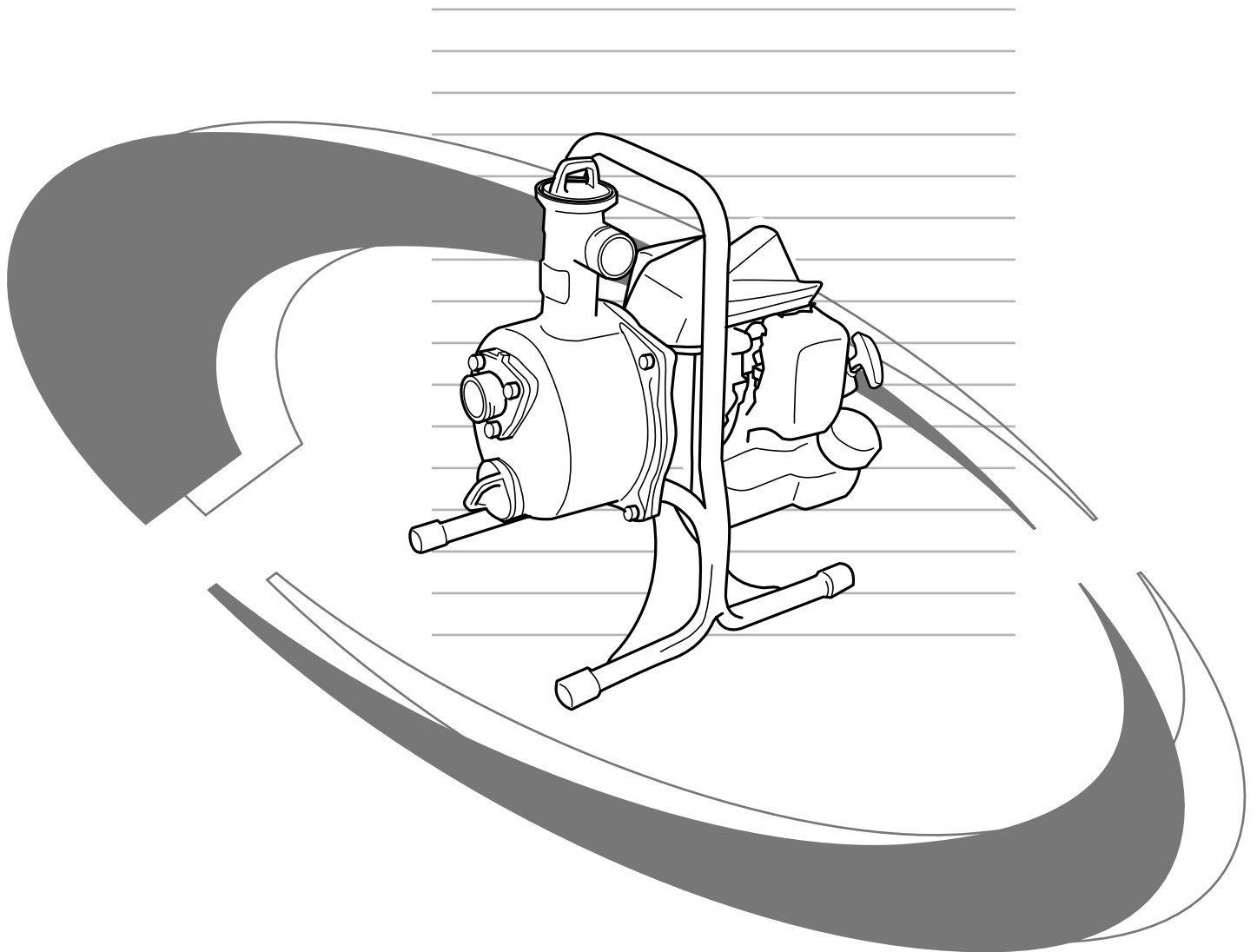



Limited Warranty Statement

All Maruyama commercial/ industrial products are warranted to the original purchaser to be free from defects in material and workmanship **from the date of purchase** for the time periods listed as follows:

Lifetime for inner drive shaft on trimmers and brushcutters and all ignition modules.

3 years for residential, non-institutional, non-income producing use.

1 year for industrial, commercial, institutional, rental and income producing use.

Maruyama AE series engines and Kawasaki TEX45/TEX54 are covered exclusively for one additional year of industrial, commercial, institutional, rental and income producing use (total of 2 years).

All other engines refer to engine manufacturer's warranty statement.

Any part of a Maruyama product found to be defective within the applicable warranty period shall, at Maruyama's option, be repaired or replaced without charge. Warranty consideration is obtained by delivering any Maruyama product believed to be defective to an Authorized Maruyama Servicing Dealer within the applicable warranty period.

The purchaser shall not be charged for diagnostic labor that leads to the determination that a warranted part is defective, if the diagnostic work is performed at a Maruyama Dealer.

Any warranted part which is not scheduled for replacement as required maintenance, or which is scheduled only for regular inspection to the effect of "repair or replace as necessary" shall be warranted for the warranty period. Any warranted part, which is scheduled for replacement as, required maintenance shall be warranted for the period of time up to the first scheduled replacement point for that part. Maruyama Mfg. Co., Inc. is liable for damages to other engine components caused by the failure of a warranted part still under warranty.

The purchaser is responsible for the performance of the required maintenance, as defined by Maruyama Mfg. Co., Inc. in the Owner's/Operator's Manual.

EMISSION-RELATED PARTS WARRANTY: In addition to the above warranty coverage, Maruyama Mfg. Co., Inc. will repair or replace, free of charge, for the original purchaser and each subsequent purchaser any emission-related part or parts found to be defective in material and workmanship for two (2) years from original retail delivery date. **Emission-related parts are the carburetor assembly, the ignition coil assembly, the ignition rotor, the spark plug, the catalytic converter and the fuel tank.** Any replacement part that is equivalent in performance and durability may be used in non-warranty maintenance or repairs, and shall not reduce the warranty obligations of Maruyama Mfg. Co., Inc.

This warranty does not cover the following:

1. Maintenance items (excluding defects in materials and workmanship) including hoses, spark plugs, starter rope, air and fuel filters, throttle cables and all pump attachments, etc.
2. Extra expenses including shipping and handling, travel, payment for lost time or pay and for any inconvenience and storage.
3. Alterations or modifications including aftermarket parts not authorized by Maruyama U.S., Inc.
4. Wear, accident, abuse, neglect, misuse, negligence, improper fuels, lubricants, fuel mixtures (when applicable), or failure to operate or maintain the product in accordance with instructions approved by Maruyama.

Repair or replacement as provided under this warranty is the exclusive remedy of the consumer. Maruyama shall not be liable for any incidental or consequential damages for breach of any express or implied warranty on these products except to the extent prohibited by applicable law. Any implied warranty of merchantability or fitness for a particular purpose on these products is limited in duration to the warranty period as defined in the limited warranty statement. Maruyama reserves the rights to change or improve the design of the product without notice and does not assume obligation to update previously manufactured products.

This warranty provides you with specific legal rights, which may vary from state to state.

It is the Owner's and Dealer's responsibility to make sure the Warranty Registration Card is properly filled out and mailed to Maruyama U.S., Inc. Proof of purchase and registration will be required in order to obtain warranty service.

To locate an Authorized Maruyama Servicing Dealer nearest you, contact:

Maruyama U.S., Inc.
PO Box 2107
Denton, TX 76202 U.S.A.
Phone 940-383-7400
maruyama@maruyama-us.com
www.maruyama-us.com

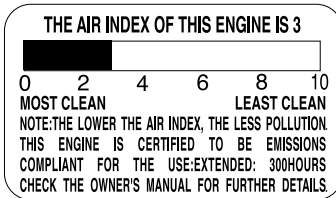
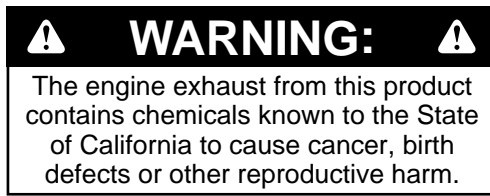

**MP2531CE-1
MP2531CE-1CA**

FEDERAL EMISSION CONTROL WARRANTY STATEMENT YOUR WARRANTY RIGHTS AND OBLIGATIONS

The U.S. Environmental Protection Agency (EPA), and Maruyama Manufacturing Company, Inc. are pleased to explain the **emission control system warranty** on your small off-road engine. New 1997 and later model year small off-road engines must be designed, built and equipped, at the time of sale, to meet the U.S. EPA regulations for small off-road engines. The equipment engine must be free from defects in materials and workmanship which cause it to fail to conform with U.S. EPA standards for the first two years of engine use from the date of sale to the ultimate purchaser. Maruyama Manufacturing Company, Inc. must warrant the emission control system on your small off-road engine for the period of time listed above provided there has been no abuse, neglect or improper maintenance of your small off-road engine.

Emission durability of 300 hours.

Your emission control system may include parts such as the carburetor or fuel injection system, the ignition system, and catalytic converter. Also included may be hoses, belts, and connectors and other emission related assemblies.

Where a warrantable condition exists, Maruyama Manufacturing Company, Inc. will repair your small off-road engine at no cost to you, including diagnosis (if the diagnostic work is performed at an authorized dealer), parts, and labor.

MANUFACTURER'S WARRANTY COVERAGE:

The 1997 and later model year small off-road engines are warranted for two years. If any emission-related part on your engine is defective, the part will be repaired or replaced by Maruyama Manufacturing Company, Inc. free of charge.

OWNER'S WARRANTY RESPONSIBILITIES:

(a) As the small off-road engine owner, you are responsible for the performance of the required maintenance listed in your owner's manual.

Maruyama Manufacturing Company, Inc. recommends that you retain all receipts covering maintenance on your small off-road engine, but Maruyama Manufacturing Company, Inc. cannot deny warranty solely for the lack of receipts or for your failure to ensure the performance of all scheduled maintenance. Any replacement part or service that is equivalent in performance and durability may be used in non-warranty maintenance or repairs, and shall not reduce the warranty obligations of the engine manufacturer.

- (b) As the small off-road engine owner, you should be aware, however, that Maruyama Manufacturing Company may deny you warranty coverage if your small off-road engine or a part has failed due to abuse, neglect, improper maintenance or unapproved modifications.
- (c) You are responsible for presenting your small off-road engine to a Maruyama Manufacturing Company, Inc. service center as soon as a problem exists. The warranty repairs should be completed in a reasonable amount of time, not to exceed 30 days.

If you have any questions regarding your warranty rights and responsibilities, you should contact Maruyama U.S., Inc. at **1-866-783-7400**.

COVERAGE

Maruyama Manufacturing Company, Inc. warrants to the ultimate purchaser and each subsequent purchaser that your small off-road engine will be designed, built and equipped, at the time of sale, to meet all applicable regulations. Maruyama Manufacturing Company, Inc. also warrants to the initial purchaser and each subsequent purchaser that your small off-road engine is free from defects in materials and workmanship which cause the engine to fail to conform with applicable regulations for a period of two years.

The 1997 and later model years, EPA requires manufacturers to small off-road engines for two years. These warranty periods will begin on the date the small off-road engine is purchased by the initial purchaser. If any emission-related part on your engine is defective, the part will be replaced by Maruyama Manufacturing Company, Inc. at no cost to the owner.

Maruyama Manufacturing Company, Inc. shall remedy warranty defects at any authorized Maruyama Manufacturing Company, Inc. engine dealer or warranty station. Any authorized work done at an authorized dealer or warranty station shall be free of charge to the owner if such work determines that a warranted part is defective. Any manufacturer-approved or equivalent replacement part may be used for any warranty maintenance or repairs on emission-related parts, and must be provided free of charge to the owner if the part is still under warranty, Maruyama Manufacturing Company, Inc. is liable for damages to other engine components caused by the failure of a warranted part still under warranty.

EPA considers emission-related warranted parts to include all the parts listed below. These warranted parts are: **the carburetor assembly, the ignition coil assembly, the ignition rotor, the spark plug, the catalytic converter, and the fuel tank.**

MAINTENANCE REQUIREMENTS

The owner is responsible for the performance of the required maintenance as defined by the Maruyama Manufacturing Company, Inc. in the owner's manual.

LIMITATIONS

This Emission Control System Warranty shall not cover any of the following:

- (a) repair or replacement required because of misuse or neglect, lack of required maintenance, repairs improperly performed or replacements not conforming to Maruyama Manufacturing Company, Inc. specifications that adversely affect performance and/or durability, and alterations or modifications not recommended or approved in writing by Maruyama Manufacturing Company, Inc., and
- (b) replacement of parts and other services and adjustments necessary for required maintenance at and after the first scheduled replacement point.

CALIFORNIA EMISSION CONTROL WARRANTY STATEMENT YOUR WARRANTY RIGHTS AND OBLIGATIONS

The California Air Resources Board (CARB), and Maruyama Manufacturing Company, Inc. are pleased to explain the emission control system warranty on your 2010 small off-road engine. In California, new small off-road engines must be designed, built and equipped to meet the State's stringent anti-smog standards. Maruyama Manufacturing Company, Inc. must warrant the emission control system on your small off-road engine for the period of time listed above provided there has been no abuse, neglect or improper maintenance of your small off-road engine.

Your emission control system may include parts such as the carburetor or fuel injection system, the ignition system, and catalytic converter. Also included may be hoses, belts, and connectors and other emission related assemblies.

Where a warrantable condition exists, Maruyama Manufacturing Company, Inc. will repair your small off-road engine at no cost to you, including diagnosis, parts, and labor.

MANUFACTURER'S WARRANTY COVERAGE:

The 1995 and later small off-road engines are warranted for two years. If any emission-related part on your engine is defective, the part will be repaired or replaced by Maruyama Manufacturing Company, Inc.

OWNER'S WARRANTY RESPONSIBILITIES:

- (a) As the small off-road engine owner, you are responsible for the performance of the required maintenance listed in your owner's manual.
Maruyama Manufacturing Company, Inc. recommends that you retain all receipts covering maintenance on your small off-road engine, but Maruyama Manufacturing Company, Inc. cannot deny warranty solely for the lack of receipts or for your failure to ensure the performance of all scheduled maintenance
- (b) As the small off-road engine owner, you should be aware, however, that Maruyama Manufacturing Company may deny you warranty coverage if your small off-road engine or a part has failed due to abuse, neglect, improper maintenance or unapproved modifications.
- (c) You are responsible for presenting your small off-road engine to a Maruyama Manufacturing Company, Inc. distribution center as soon as a problem exists. The warranty repairs should be completed in a reasonable amount of time, not to exceed 30 days.

If you have any questions regarding your warranty rights and responsibilities, you should contact Maruyama U.S., Inc. at **1-866-783-7400**.

Emission System Parts

Exhaust Emission

Carburetor
Muffler
Catalytic Converter
Ignition Coil / Magneto
Spark Plug
Air Filter
EGR Valve (piston)
Fuel Filter

Evaporative Emission

Fuel Tank

Contents

| | Page |
|--------------------------------------|-------------|
| 1. Limited Warranty Statement | 1 |
| 2. Federal Emission Control | 3 |
| 3. California Emission Control | 5 |
| 4. Introduction | 7 |
| 5. Specifications | 8 |
| 6. Product Description | 8 |
| 7. Standard Accessories | 9 |
| 8. Safety | 10 |
| 9. Assembly Instructions | 12 |
| 10. Before Operation | 13 |
| 11. Operating The Water Pump | 17 |
| 12. Carburetor Adjustment | 19 |
| 13. Maintenance | 20 |
| 14. Storage | 23 |
| 15. Troubleshooting | 25 |
| 16. Maintenance Period | 26 |

Introduction

Thank you for purchasing a Maruyama product.

Maruyama, its distributors, and dealers want you to be completely satisfied with your new product. Please feel free to contact your local Authorized Service Dealer for help with service, genuine Maruyama parts, or other information you may require.

Whenever you contact your Authorized Service Dealer or the factory, always know the serial number of your product. This number will help the Service Dealer or Service Representative provide exact information about your specific product. You will find the model and serial number located in a unique place on the product (Product Description on page 9).

For your convenience, write the product model name and serial number in the space below.

| |
|-------------------------|
| Model Name _____ |
| Serial No. _____ |

Read this manual carefully to learn how to operate and maintain your product correctly. Reading this manual will help you and others avoid personal injury and damage to the product.

Although Maruyama designs, produces and markets safe, state-of-the-art products, you are responsible for using the product properly and safely. You are also responsible for training persons who you allow to use the product about safe operation.

Specifications







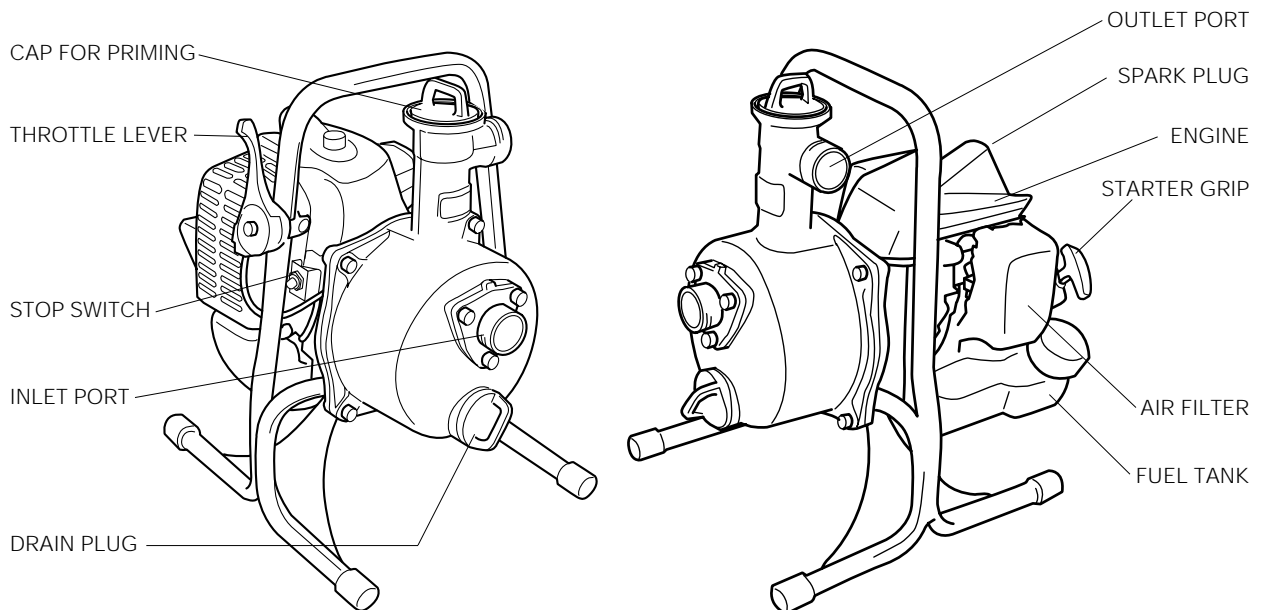

| Models | | MP2531CE-1, MP2531CE-1CA |
|--------|-------------------------|---|
| Pump | Length x Width x Height | 304 x 251 x 336mm (12.0 x 9.9 x 13.2 in.) |
| | Dry Weight | 5.5 kg (12 lbs.) |
| | Inlet/Outlet Dia | 25 mm (1 in.) |
| | Connection Thread | PF 1 |
| | Maximum Outlet Flow | 113 ℓ /min (30 gal/min) |
| | Maximum Head | 36 m (118 ft.) |
| Engine | Displacement | 30.1 cc |
| | Fuel Tank Capacity | 0.6 ℓ (0.63 qts.) |
| | Carburetor | Walbro Diaphragm Type |
| | Ignition System | Solid State |
| | Spark Plug: | NGK BPM8Y |
| | Spark Plug Gap | 0.6 ~ 0.7 mm (0.024 ~ 0.028 in.) |
| | Gas to Oil Ratio | 50:1 |
| | CARB Approved | Tier 3 |

Emission durability of 300 hours.

Product Description

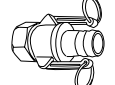

Standard Accessories

| | Part Name | Q'ty | Remarks |
|---|-------------------|------|-------------|
|  | Suction Hose | 1 | 3 m |
|  | Nut | 2 | 1 in. |
|  | Packing | 2 | 1 in. |
|  | Coupling | 2 | 1 in. |
|  | Coupling | 1 | 3/4 in. |
|  | Coupling | 1 | 5/8 in. |
|  | Strainer | 1 | |
|  | One Touch Coupler | 2 | 1 in |
|  | Clamp | 3 | |
|  | Box Spanner | 1 | 13 x 19 x ⊕ |

The Maruyama warning system in this manual identifies potential hazards and has special safety messages that help you and others avoid personal injury, even death. DANGER, WARNING and CAUTION are signal words used to identify the level of hazard. However, regardless of the hazard, be extremely careful.

DANGER signals an extreme hazard that will cause serious injury or death if the recommended precautions are not followed.

WARNING signals a hazard that may cause serious injury or death if the recommended precautions are not followed.

CAUTION signals a hazard that may cause minor or moderate injury if the recommended precautions are not followed. Two other words are also used to highlight information. “Important” calls attention to special mechanical information and “Note” emphasizes general information worthy of special attention.

Safety

Operator Safety

1. Read and understand this Operator’s Manual before using this product. Be thoroughly familiar with the proper use of this product.
2. Never allow children to operate the Water Pump. It is not a toy. Never allow adults to operate the unit without first reading the Operator’s Manual.
3. Never operate this Water Pump when you are tired, ill, or under the influence of alcohol, drugs or medication.
4. Never start or run the engine inside a closed room or building. Breathing exhaust fumes can cause death.



Fuel safety

1. Gasoline is highly flammable and must be handled and stored carefully. Use a container approved for fuel to store gasoline and/or fuel/oil mixture.
2. Mix and pour fuel outdoors, where there are no sparks or flames.
3. Do not smoke near fuel or the water pump, or while using the water pump.
4. Do not overfill the fuel tank. Stop filling 1/4-1/2 inch (6mm-13mm) from the top of the tank.
5. Wipe up any spilled fuel before starting the engine.

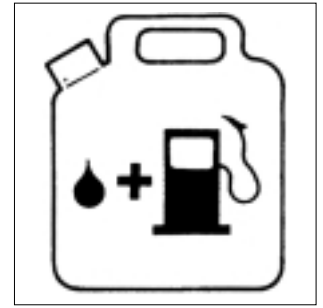

6. Move the water pump at least 10 feet (3m) away from the fueling location before starting engine.
7. Do not remove the water pump fuel tank cap while the engine is running or right after stopping the engine.
8. Allow the engine to cool before refueling.
9. Empty the fuel tank before storing the water pump. Fuel should be emptied after each use. Fuel left in the tank during storage may leak.
10. Store fuel and water pump away from open flame, sparks and excessive heat. Make sure fuel vapors cannot reach sparks or open flames from water heaters, furnaces, electric motors, etc.

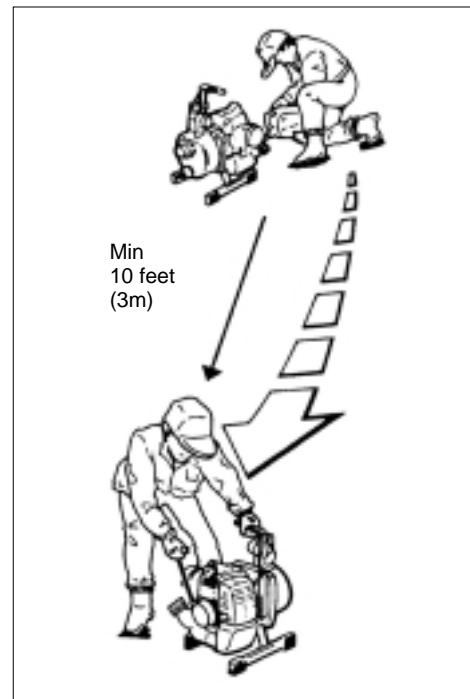

Assembly Instructions

1. Install a rubber packing onto one of the 1 inch hose fittings. Slide a hose fitting nut over the fitting. Slide two hose clamps over the suction hose. Attach the hose coupler assembly and strainer to either end and tighten the hose clamps.

Due to different operator requirements, the discharge hose is not provided. Three hose fittings and the one touch coupler are supplied with water pump to be used with either 5/8, 3/4 or 1 inch inside diameter hose. Select an discharge hose that is the suitable diameter and length for your application.

Once you have selected the outlet hose, assemble the appropriate hose fitting, packing and nut and secure the fitting to the hose with the hose clamp.

Suction Hose Assembly (1 inch Hose Fitting)

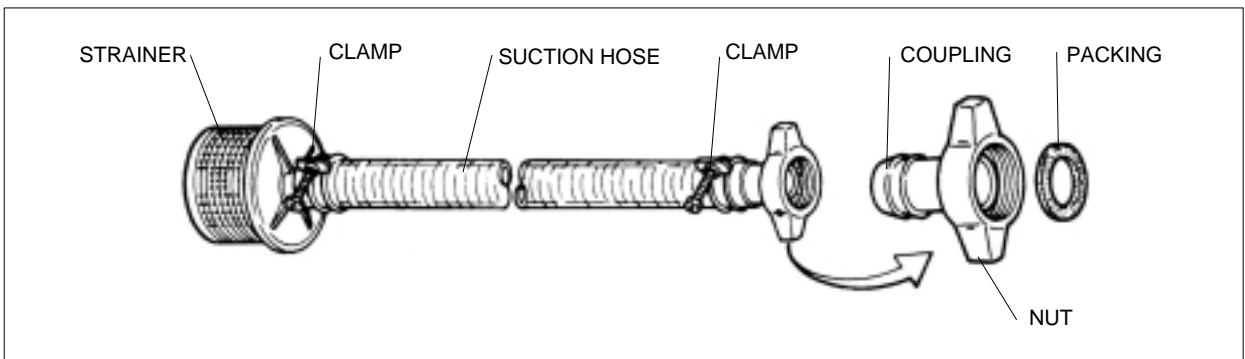

Discharge Hose Assembly (One Touch Coupler)

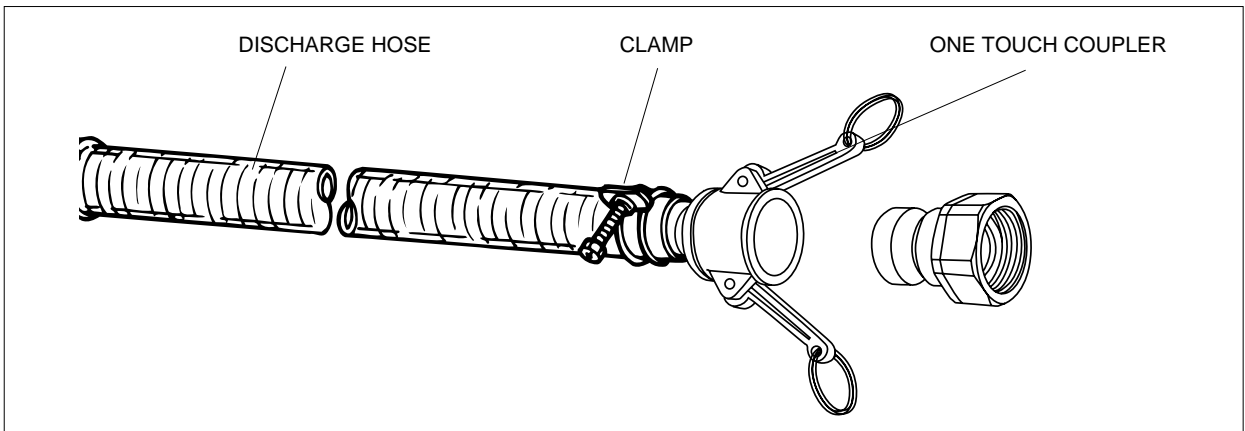

2. Fix the suction hose and the outlet hose to the pump, as shown.

WARNING: Always use the suction hose and strainer provided among the standard accessories. If another suction hose is used, it must be used with the strainer.

A crush resistant hose is recommended.

During operation, if the suction hose is crushed, it can cause the pump to fail.

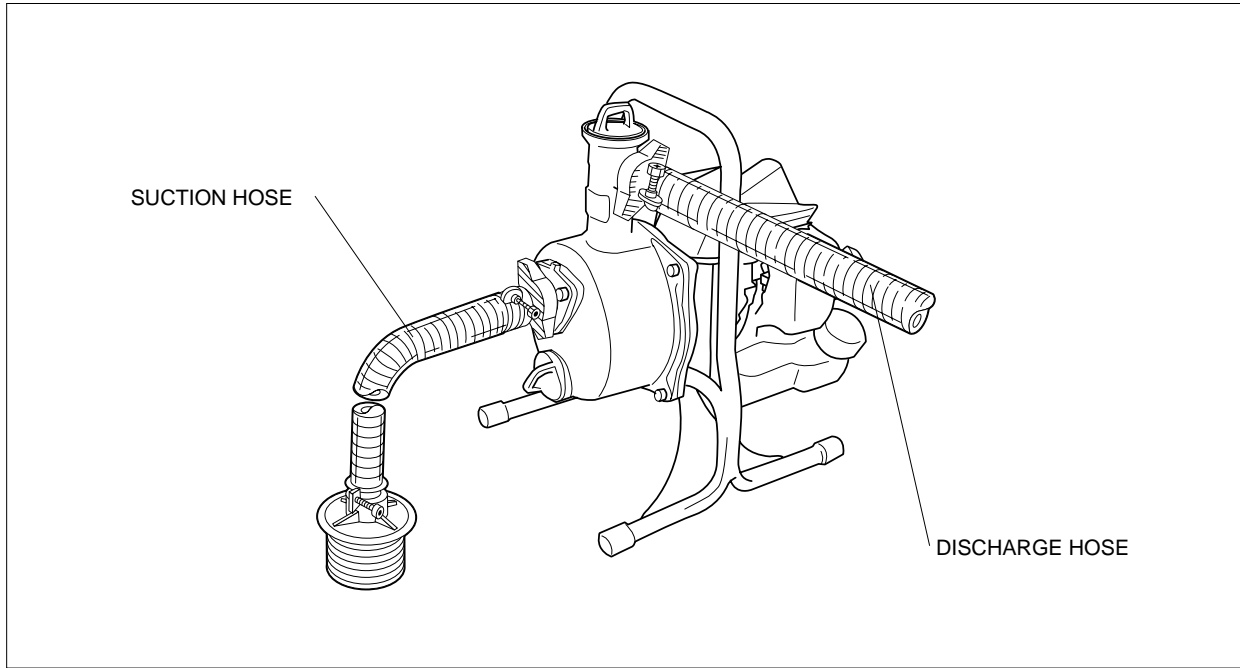

Before Operation

PUMP SECTION

1. Check that there are no loose screws or components on the machinery.
2. Place the pump on a level surface, but not immediately next to the water supply.
If the pump must be placed on a sloping or inclined surface, a level platform must be used. Be sure to secure the pump adequately.
3. Where the weight of the suction hose causes the pump to tilt or move, secure the pump adequately.
4. Always attach the strainer to the end of the suction hose. If the pump is operated without the strainer, pebbles and other materials will be sucked into the pump and could cause damage and pump failure.
5. Be sure that the strainer is completely submerged, but not in contact with sandy or muddy bottom surfaces.
6. Secure the suction and outlet hoses tightly to the pump to avoid sucking air.

ENGINE SECTION

Oil and Fuel

⚠ DANGER

POTENTIAL HAZARD

- In certain conditions gasoline is extremely flammable and highly explosive.

WHAT CAN HAPPEN

- A fire or explosion from gasoline can burn you, others, and cause property damage.

HOW TO AVOID THE HAZARD

- Use a funnel and fill the fuel tank outdoors, in an open area, when the engine is cold. Wipe up any gasoline that spills.
- Do not fill the fuel tank completely full. Add gasoline to the fuel tank until the level is 1/4" to 1/2" (6 mm to 13 mm) below the bottom of the filler neck. This empty space in the tank allows gasoline to expand.
- Never smoke when handling gasoline, and stay away from an open flame or where gasoline fumes may be ignited by a spark.
- Store gasoline in an approved container and keep it out of the reach of children.
- Never buy more than a 30-day supply of gasoline.

1. Do not smoke near fuel.
2. Mix and pour fuel outdoors and where there are no sparks or flames.
3. Always shut off the engine before refueling. Never remove the fuel tank cap while the engine is running or just right after stopping the engine.
4. Always open the fuel tank cap slowly to release any possible overpressure inside the tank.

⚠ WARNING

POTENTIAL HAZARD

- Gasoline contains gasses that can build up pressure inside a gas tank.

WHAT CAN HAPPEN

- Fuel can be sprayed on you when removing gas cap.

HOW TO AVOID THE HAZARD

- Remove fuel cap slowly to avoid injury from fuel spray.

5. Do not overfill the fuel tank. Stop filling 1/4-1/2 inch (6 mm-13 mm) from the top of the tank.
6. Tighten the fuel tank cap carefully but firmly after refilling.
7. Wipe up any spilled fuel before starting the engine.
8. Move the Water Pump at least 10 feet (3 m) away from the fueling location and fuel storage container before starting the engine.

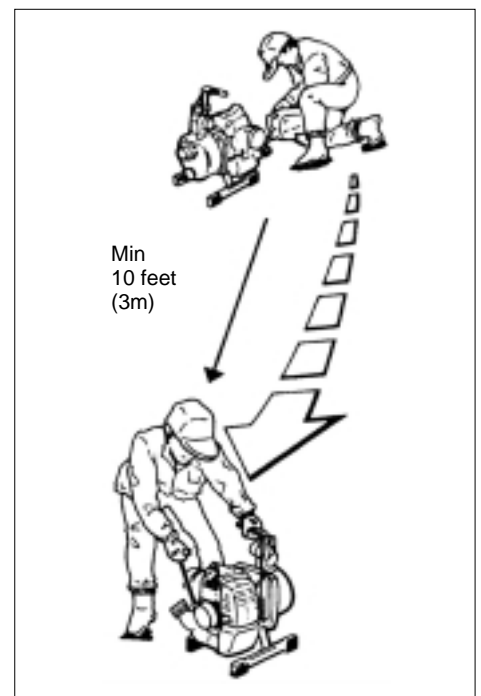

Recommended Oil Type

Only use a two-cycle engine oil formulated for use in high-performance, air-cooled two-cycle engines. Maruyama brand 2-cycle oil is formulated for use in high-performance, air-cooled two-cycle engines.

IMPORTANT: Do not use National Marine Manufacturer's Association (NMMA) or BIA certified oils. This type of 2-cycle engine oil does not have the proper additives for air-cooled, 2-cycle engines and can cause engine damage.

Do not use automotive motor oil. This type of oil does not have the proper additives for air-cooled, 2-cycle engines and can cause engine damage.

Recommended Fuel Type

Use clean, fresh lead-free gasoline, including *oxygenated* or *reformulated* gasoline, with an octane rating of 89 or higher. To ensure freshness, purchase only the quantity of gasoline that can be used in 30 days. Use of lead-free gasoline results in fewer combustion chamber deposits and longer spark plug life. Use of premium grade fuel is not necessary or recommended.

Use of Fuel Additives

IMPORTANT: NEVER USE METHANOL, GASOLINE CONTAINING METHANOL, GASOHOL CONTAINING MORE THAN 10% ETHANOL, PREMIUM GASOLINE, OR WHITE GAS BECAUSE ENGINE FUEL SYSTEM DAMAGE COULD RESULT.

DO NOT USE FUEL ADDITIVES OTHER THAN THOSE MANUFACTURED FOR FUEL STABILIZATION DURING STORAGE SUCH AS MARUYAMA'S STABILIZER/CONDITIONER OR A SIMILAR PRODUCT. MARUYAMA'S STABILIZER/CONDITIONER IS A PETROLEUM DISTILLATE BASED CONDITIONER/STABILIZER.

MARUYAMA DOES NOT RECOMMEND STABILIZERS WITH AN ALCOHOL BASE SUCH AS ETHANOL, METHANOL OR ISOPROPYL. ADDITIVES SHOULD NOT BE USED TO TRY TO ENHANCE THE POWER OR PERFORMANCE OF MACHINE.

Mixing Gasoline And Oil

IMPORTANT: The engine used on this Water Pump is of a 2-cycle design. The internal moving parts of the engine, i.e., crankshaft bearings, piston pin bearings and piston to cylinder wall contact surfaces, require oil mixed with the gasoline for lubrication.

Failure to add oil to the gasoline or failure to mix oil with the gasoline at the appropriate ratio will cause major engine damage which will void your warranty.

For your fuel premix, use Maruyama Premium 2-cycle Oil Mix, or equivalent ISO-L-EGD & JASO FC oil with a minimum 89 octane high quality gasoline. Maruyama 2-cycle oil is specially formulated to meet the requirements of high-performance, low-emission air-cooled 2-cycle engines. Use of other oils may lead to service issues which may not be covered by your warranty.

Fuel Mixture

The fuel: oil ratio is 50 parts gasoline to 1 part oil or 50:1.

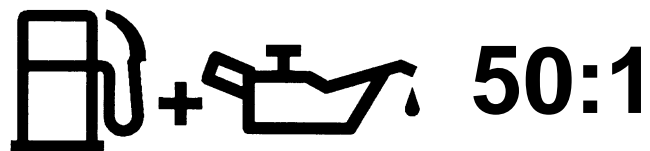

Note: Never use a mixing ratio less than 50:1 regardless of the oil package mixing instructions. Ratios less the 50:1, (for example, 60:1, 80:1, 100:1), reduce the amount of lubrication to the internal moving parts of the engine and can cause damage.

Fuel Mixture Chart

| Gasoline | 50:1 2-cycle oil |
|-----------|------------------|
| 1 gallon | 2.6 oz. |
| 2 gallons | 5.1 oz. |
| 5 gallons | 12.8 oz. |
| 1 litre | 20 ml |
| 5 litre | 100 ml |

Mixing Instructions

IMPORTANT: Never mix gasoline and oil directly in the Water Pump fuel tank.

1. Always mix fuel and oil in a clean container approved for gasoline.
2. Mark the container to identify it as fuel mix for the Water Pump.
3. Use regular unleaded gasoline and fill the container with half the required amount of gasoline.
4. Pour the correct amount of oil into the container then add the remaining amount of gasoline.
5. Close the container tightly and shake it momentarily to evenly mix the oil and the gasoline before filling the fuel tank on the Water Pump.
6. When refilling the Water Pump fuel tank, clean around the fuel tank cap to prevent dirt and debris from entering the tank during cap removal.
7. Always shake the premix fuel container momentarily before filling the fuel tank.
8. Always use a spout or funnel when fueling to reduce fuel spillage.
9. Fill the tank only to within 1/4-1/2 inch (6 mm-13 mm) from the top of the tank. Avoid filling to the top of the tank filler neck.

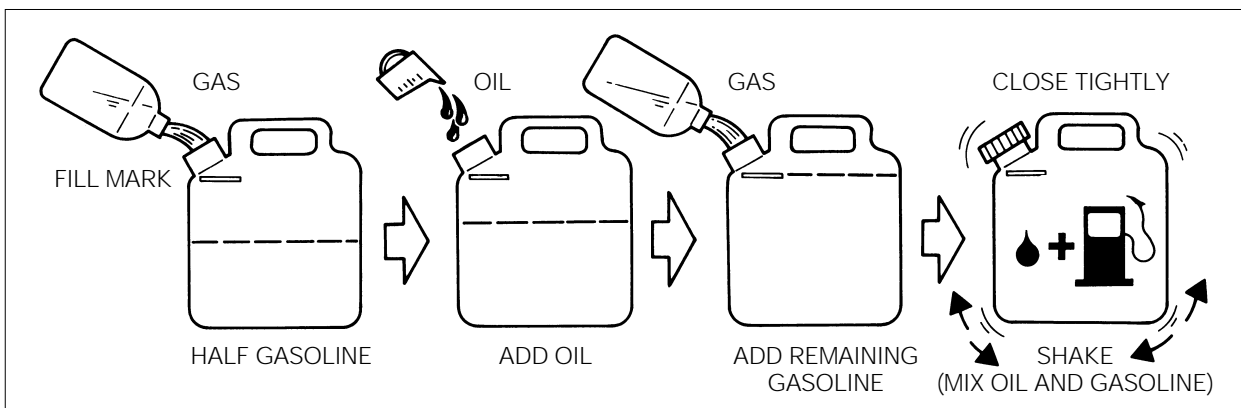

Operating The Water Pump

1.

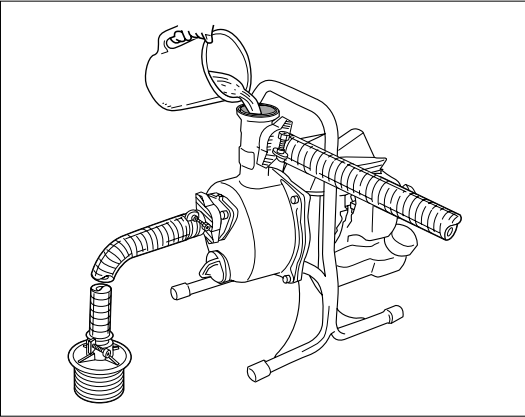

Remove the water inlet cap

Fill the pump casing with priming water until it is full.

Shake the equipment slightly so that trapped air is easily removed.

2.

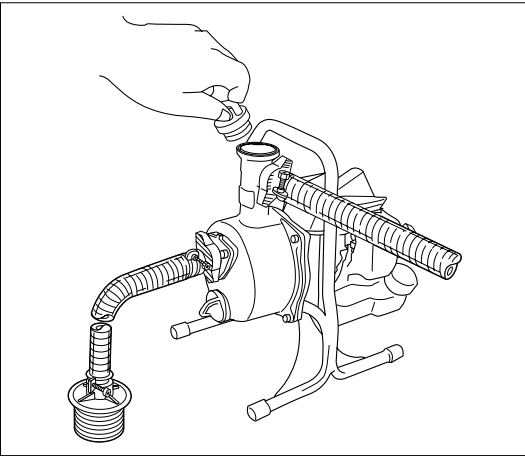

Fasten the cap tightly.

WARNING: (1) Never start the engine without first priming the pump. If the engine is started without first priming the pump with water, the water pump mechanical seal will be permanently damaged.

(2) Before running the engine, be sure to immerse the suction hose in the water. Running the engine with only priming water will cause the temperature of the priming water to rise, damaging the mechanical seal.

3. After the engine starts, the pump will gradually start suction. Once suction starts, let the pump run 2-3 minutes to warm up, and then operate it at the specified rpm setting.
4. To stop water pump operation, press the engine stop button.
5. When the engine is restarted, the pump will operate without priming, but the level of the water inside the casing must be checked before starting in the event that the suction hose end is exposed, the installation site is changed, or the pump has not been used for a long time.

Starting And Stopping

Before Starting The Engine

1. Fill the fuel tank as instructed in the Before Operation section of this manual (page14).
2. Rest the Water Pump on the ground.
3. Keep all bystanders, children and animals away from the working area.

Cold Starting Procedure

This Water Pump is equipped with a fuel primer and a choke system. To start a “cold” engine properly, perform the following procedure:

1. Pump the primer bulb at the bottom of the carburetor until fuel can be seen flowing through the fuel return line to the fuel tank.
(Flowing fuel should be almost clear, not foamy or full of bubbles.)

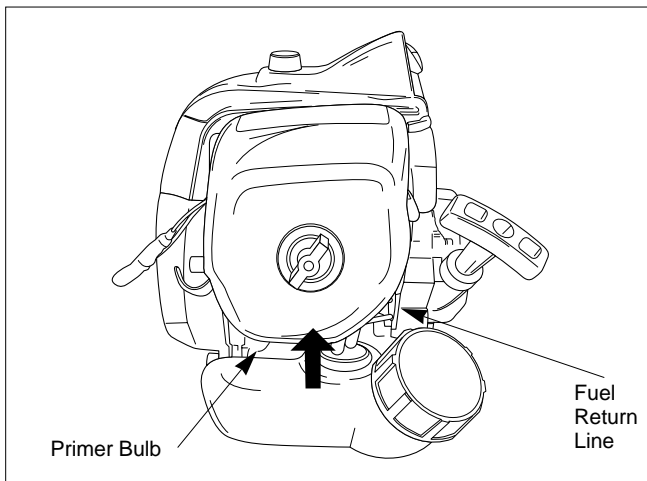

2. Move the choke lever to the closed (⊥) position and move the stop switch to the “ON” position.
3. With the stop switch “ON”,and the throttle lever positioned at 1/3 throttle position, then pull the starter grip.
4. After the engine starts, move the throttle lever to the idle position, then move the choke lever to the open (→) position.

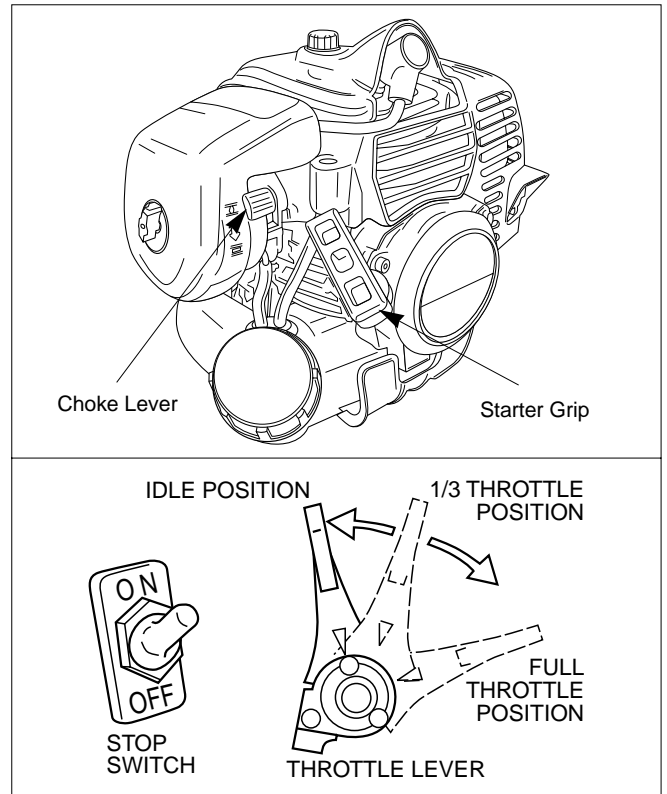

If the engine stops running before you move the choke lever to the open (→) position:

- A. Go ahead and open the choke.
- B. Make sure the throttle lever is set to the 1/3 throttle position.
- C. Pull the starter grip until the engine starts.

⚠ WARNING

POTENTIAL HAZARD

- **The components of your recoilstarter assembly are under high spring tension. If improperly disassembled these parts may strike you with considerable force, possibly causing personal injury.**

WHAT CAN HAPPEN

- **Contact with the parts can cause severer personal injury.**

HOW TO AVOID THE HAZARD

- **Never attempt to disassemble your recoil starter assembly yourself. Always consult your authorized Maruyama dealer for repair by qualified service technicians.**

Hot Restart

To start an engine that is already warmed up (hot restart), or if the ambient temperature exceeds 68°F (20°C):

1. Pump the primer bulb at the bottom of the carburetor until fuel can be seen flowing through the fuel return line to the fuel tank.
2. Move the choke lever to the open (☰) position and move the stop switch to the “ON” position.
3. Leave the throttle lever in the idle position and pull the starter grip.
4. If the engine fails to start after three to four pulls, follow the instruction in the Cold Starting Procedure section (page 18).

If the engine fails to start after you follow the above procedures, contact an authorized Maruyama dealer.

To Stop The Engine:

1. Move throttle lever to the idle position.
2. Move the stop switch to the “OFF” position.

IMPORTANT: Except emergency, do not stop engine while it runs fast. It may damage the engine. Move the throttle lever at idle position first, then move the stop switch to “OFF” position.

IMPORTANT: In case of the stop switch failure and the engine continue to run, move the choke lever to the closed (⊥) position to stop the engine.

Carburetor Adjustment

This water pump is equipped with non-adjustable fuel mixture carburetor. The engine idle speed is the only adjustment accessible to the Operator.

CAUTION: The water pump impeller is spinning during idle speed adjustment.

Never start the engine without water in the pump housing.

Running the engine without water in the pump housing will cause serious damage.

Engine Idle Speed:

The engine idle speed should be 2,700-3,300 rpm.

The engine idle speed is adjusted by rotating the idle speed screw on the carburetor.

Turning the idle speed screw in (clockwise) increase engine speed while turning the screw out decreases engine speed.

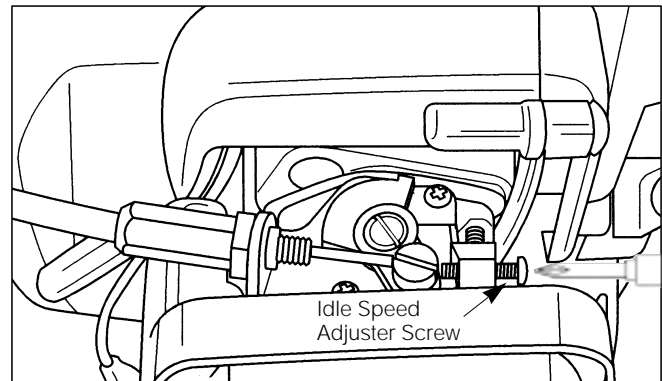

Maintenance

Maintenance, replacement or repair of emission control devices and systems may be performed by any repair establishment or individual; however, warranty repairs must be performed by a dealer or service center authorized by Maruyama Manufacturing Company, Inc. The use of parts that are not equivalent in performance and durability to authorized parts may impair the effectiveness of the emission control system and may have a bearing on the outcome of a warranty claim.

Pump

1. After the pump has been used with muddy water, be sure to run it with clean water for a few minutes to clean the interior of the pump before stopping operation.
2. Where outside temperatures drop to freezing or below, be sure to drain all water from the pump before storage.
3. When the unit is not to be used for a long period of time, clean the pump interior thoroughly, remove all remaining moisture, and then store it covered in a dry, cool, dark place.

Air Filter

Maintenance Interval

- The air filter should be cleaned **daily**, or more often when working in extremely dusty conditions.
- Replace after every 100 hours of operation.

Air Filter Cleaning

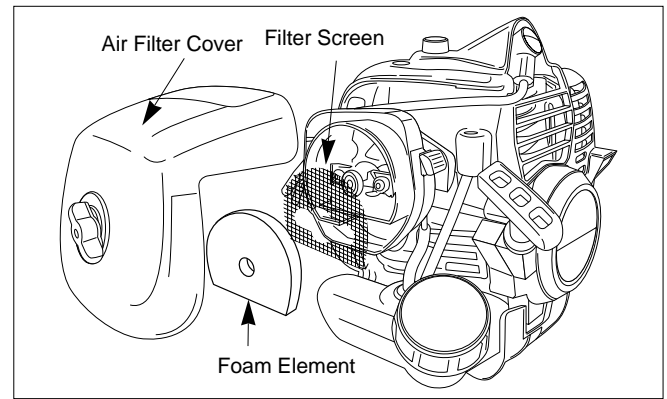

1. Loosen the knob and remove the air filter cover.
2. Remove the foam element and filter screen from the air filter body.
3. Clean the foam element and filter screen with warm, soapy water. Let the screen and element dry completely.
4. Apply a light coat of SAE 30 motor oil to the foam element and squeeze out all excess oil.
5. Reassemble the filter screen and foam element to the air filter body.
6. Reinstall the air filter cover and tighten the knob.

Fuel Filter

Maintenance Interval

The fuel filter should be replaced after every 100 hours of operation.

Fuel Filter Replacement

The fuel filter is attached to the end of the fuel pick-up hose inside the fuel tank.

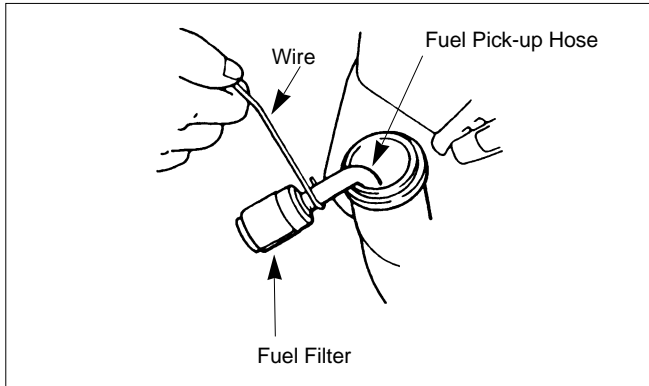

To replace the fuel filter:

1. Make sure the fuel tank is empty.
2. Remove the fuel cap.
3. Using a wire hook, gently pull the fuel filter out through the fuel filler opening.
4. Grasp the fuel hose next to the fuel filter fitting and remove the filter, but do not release the hose.
5. While still holding on to the fuel hose, attach the new fuel filter.
6. Drop the new fuel filter back into the fuel tank.
7. Make sure that the fuel filter is not stuck in a corner of the tank, and that the fuel hose is not doubled over (kinked) before refueling.

Spark Plug

Maintenance Interval

- The spark plug should be removed from the engine and checked after each 25 hours of operation.
- Replace the spark plug after every 100 hours of operation.

Spark Plug Maintenance

1. Twist the high tension lead boot on the spark plug back and forth a couple of times to loosen the boot, then pull the boot off of the spark plug.
2. Remove the spark plug.
3. Clean the electrodes with a stiff brush.

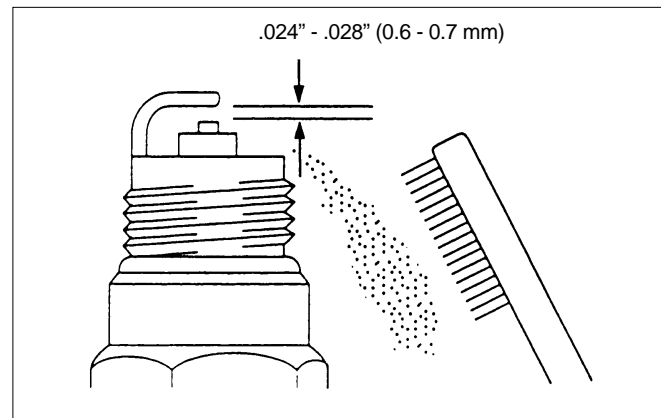

4. Adjust the electrode air gap to .024-.028 in (0.6-0.7 mm).
5. Replace the spark plug if it is oil-fouled, damaged, or if the electrodes are worn down.
6. Do not overtighten the spark plug when installing. The tightening torque is 95-148 in. lbs. (10.7-16.6 N·m).

Cylinder Cooling Fins

Maintenance Interval

The cylinder cooling fins should be cleaned after every 25 hours of operation, or once a week, whichever comes first.

Air must flow freely around and through the cylinder cooling fins to prevent engine overheating. Leaves, grass, dirt and debris buildup on the fins will increase the operating temperature of the engine, which can reduce engine performance and shorten engine life.

Cooling Fin Cleaning

1. With the engine at ambient (room) temperature, loosen the knob and remove the air cleaner cover.

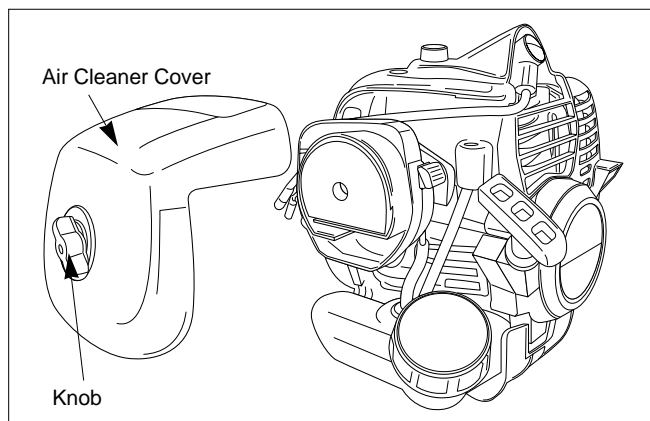

2. Twist the high tension lead boot on the spark plug back and forth a couple of times to loosen the boot, then pull the boot off of the spark plug.
3. Loosen the knob and lift off the cylinder cover.
4. Clean all dirt and debris from the cooling fins and from around the cylinder base.
5. Reinstall the fan cover and the cleaner cover.

Spark Arrester

⚠ WARNING

POTENTIAL HAZARD

- **Muffler surface becomes hot when Water Pump is in operation and remains hot for some time after the engine is shut off.**

WHAT CAN HAPPEN

- **Contact with hot muffler surfaces could cause a burn.**

HOW TO AVOID THE HAZARD

- **Make sure the muffler is cool before inspecting and cleaning the spark arrester.**

Maintenance Interval

- The spark arrester should be inspected and cleaned after every 25 hours of use.
- Replace the screen if it cannot be thoroughly cleaned, or if it is damaged.

Spark Arrester Maintenance

1. With the engine at ambient (room) temperature, Remove the tapping screw, and remove the cover.
2. Twist the high tension lead boot on the spark plug back and forth a couple of times to loosen the boot, then pull the boot off of the spark plug.
3. Loosen the knob and lift off the cylinder cover.

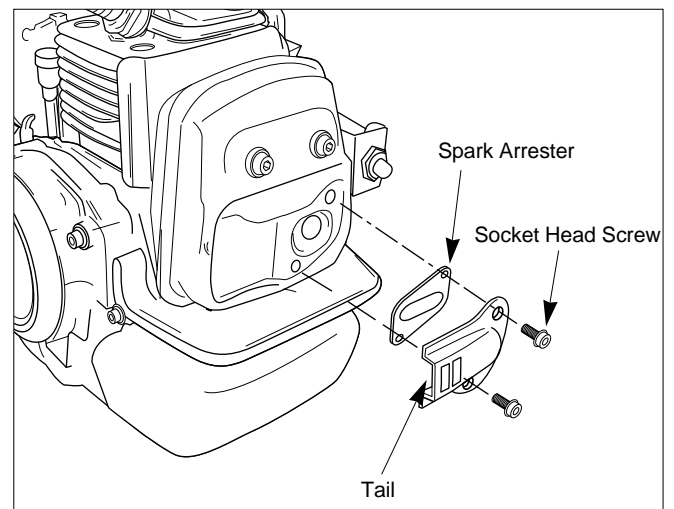

4. Remove and clean the tail, gasket and spark arrester with a safety solvent and a stiff brush. If any part cannot be thoroughly cleaned, it must be replaced.
5. Reinstall the spark arrester and tail onto the muffler, then reinstall and tighten the two socket head screws.
6. Reinstall the cylinder cover and the air cleaner cover.

Exhaust Muffler

Maintenance Interval

The muffler should be inspected and cleaned after each 100 hours of use.

Muffler Maintenance

1. With the engine at ambient (room) temperature, loosen the knob and remove the air cleaner cover.
2. Twist the high tension lead boot on the spark plug back and forth a couple of times to loosen the boot, then pull the boot off of the spark plug.
3. Loosen the knob and lift off the cylinder cover.
4. Remove the spark arrester (see spark arrester maintenance), Clean the muffler with a stiff brush.
5. Reinstall the spark arrester and tail onto muffler, then reinstall and tighten the two socket head screws.
6. Reinstall the cylinder cover and the air cleaner cover.

IMPORTANT: Be careful not to allow any dirt or debris to fall into the exhaust port, as this can cause engine damage.

Storage

For long term storage of the Water Pump:

PUMP SECTION

1. Drain water from the pump completely.
2. Remove Suction hose and Discharge hose from pump.

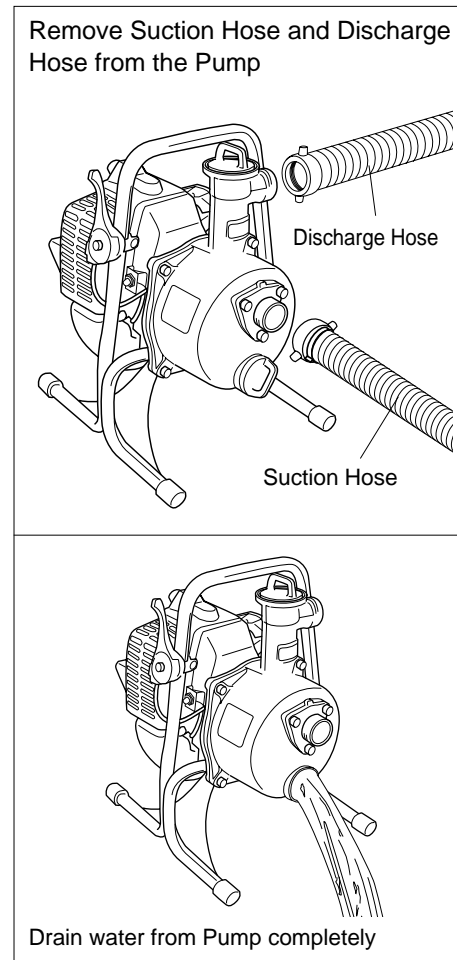

IMPORTANT: Do not wash the pump in water. It may damage the engine.

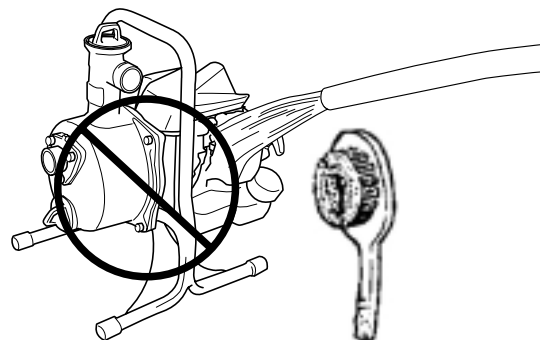

Do not wash the pump in water

ENGINE SECTION

1. Empty the fuel tank into a suitable fuel storage container.
2. Pump the primer bulb on the carburetor until all fuel is discharged through the clear fuel return hose.
3. Run the engine to remove any fuel that may remain in the carburetor.
4. Perform all regular maintenance procedures and any needed repairs.
5. Remove the spark plug and squirt a very small amount of oil into the cylinder.
6. Pull the starter grip once.
7. Slowly pull the starter grip to bring the piston to the top of the cylinder (TDC).
8. Reinstall the spark plug.
9. Store the Water Pump in a dry place away from excessive heat, sparks or open flame.

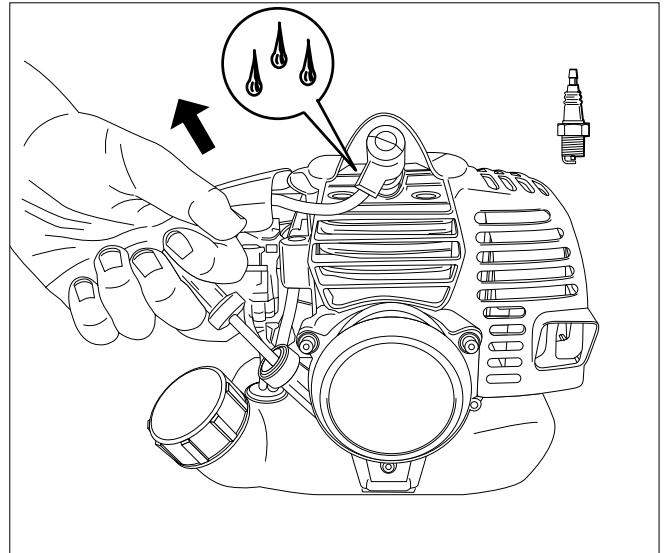

⚠ CAUTION

POTENTIAL HAZARD

- **Oil may squirt out of the spark plug opening when you pull the starter grip.**

WHAT CAN HAPPEN

- **Oil can cause eye injuries.**

HOW TO AVOID THE HAZARD

- **Protect your eyes and keep your face away from the spark plug opening.**

Troubleshooting

| | Problem | Cause | Action |
|---|--|---|---|
| Pump | Pump doesn't rotate | Engine doesn't move | Refer to engine troubleshooting. |
| | | Impeller rusted | Disassemble and repair |
| | | Debris is stuck in Impeller. | Disassemble and clean |
| | No suction or suction time is long | Air is being drawn in | Check all connections and tighten them. |
| | | Priming water is not sufficient | Fill the pump casing with priming water until it is full |
| | | Mechanical seal failure | Replace mechanical seal |
| | | Engine rpm is too low | Increase engine rpm |
| | | Pump position is too high from water source | Place pump near water source Replace suction hose |
| | | Suction hose is damaged or folded | |
| | | Strainer or hose is clogged | Check and clean |
| | Low discharge volume Low discharge pressure | Air is being drawn in | Check all connections and tighten them. |
| | | Engine rpm is too low | Increase engine rpm |
| | | Pump position is too high from water source | Place pump near water source |
| | | Impeller is worn | Replace Impeller |
| | | Suction hose diameter is too small | Use bigger diameter suction hose |
| Debris is stuck in Impeller. | | Disassemble and clean | |
| Strainer or hose is clogged | | Check and clean | |
| Engine | Engine Will Not Start | STOP switch set to off position | Move switch to on position |
| | | Empty fuel tank | Fill fuel tank |
| | | Primer bulb wasn't pushed enough | Press primer bulb until fuel flows through fuel return line |
| | Engine flooded | Use warm engine starting procedure | |
| Engine Will Not Idle | Idle speed set incorrectly | Set idle speed | |
| Engine Lacks Power or Stalls When Cutting | Throttle wire has come loose | Dirty air filter | Tighten throttle wire Clean or replace air filter |
| | | Clogged spark arrester or exhaust port. | Clean spark arrester or exhaust port |

If further assistance is required, contact your local authorized Maruyama service dealer.

Maintenance Period

| | Maintenance | Daily | Every 20 hours | Every 50 hours | Every 100 hours |
|---|--|--|-------------------|-------------------|--------------------|
| | Check and replenish fuel | ● | | | |
| | Check for fuel leakage | ● | | | |
| | Check bolts, nuts and screws for tightness or missing | ● | | | |
| | Tighten bolts and nuts | | | ● | |
| ■ | Clean air filter element | | ● | | |
| | Clean spark plug and adjust electrode gap | | | ● | |
| ■ | Remove dust and dirt from cylinder fins | | | ● | |
| ● | Remove carbon deposits in exhaust port | | | ● | |
| ● | Clean spark arrester | | | ● | |
| | Replace fuel filter | | | | ● |
| ● | Remove carbon deposits on piston head and combustion chamber | | | | ● |
| ● | Remove carbon deposits in transfer ports | | | | ● |
| | Replece fuel tube, fuel tank cap gasket | It is recommended to replace every 3 years | | | |

●: Service to be performed by an authorized Maruyama engine dealer.

■: Service more frequently under dusty conditions.

NOTE:

The service intervals indicated are to be used as a guide.

Service to be performed more frequently as necessary depending on operating condition.

Use Maruyama standard 50:1 two-cycle engine oil.

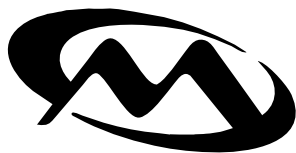

Maruyama U.S., Inc.

3570 Shelby Lane
Denton, TX 76207 U.S.A
P.O. Box 2107
Denton, TX 76202 U.S.A
Phone 940-383-7400
Fax 940-383-7466

www.maruyama-us.com

284680-03 10.10 TAP/M