

OPERATING INSTRUCTIONS (463757)
463743



Bump n Feed™ Nylon cutting head for use with trimmers and brushcutters.

You have selected the revolutionary new M-Twist trimmer head, brought to you by Maruyama—manufacturer of the top-quality outdoor power equipment used by professionals the world over. Before use, please ensure proper operation of your new M-Twist trimmer head by carefully reading and following the instructions in this manual.

WARNING!

Like all trimmer heads, the M-Twist rotates and very high RPM. Thus, there is the possibility that foreign objects such as rocks and other debris can be thrown from the cutting area. Use caution when operating near parked cars and windows. Keep bystanders as a safe distance—at least 15 meters from your work area. If the trimmer head contacts a solid object such as a concrete or stone, the head could suffer damage and broken bits can be thrown. If you damage your head, cease operating and inspect the M-Twist head. Repair or replace as necessary.

PRECAUTION

Read and follow the instructions in this manual whenever you operate the M-Twist trimmer head. The M-Twist is designed for cutting grass and weeds with nylon cutting line on a trimmer or brushcutter. Do not use this product for any other purpose. If you lend this product to another person, this manual must accompany the product. All operators must be fully aware of operating instructions. Keep these instructions in a convenient location, where the information is readily available to you and others who might use the M-Twist head. Read and follow the operating instructions for your trimmer or brushcutter. These are provided by the equipment manufacturer.

Wear proper protective clothing and protective equipment such as goggles, face shield, gloves, boots and ear protection when operating your trimmer or brushcutter with the M-Twist trimmer head. Your trimmer or brushcutter must be equipped with a safety strap and debris shield. (Fig.2)

Your M-Twist trimmer head features a visible wear bar near the eyelets. When this wear bar disappears from long-term usage, you must replace the cover. Also, if holes or cracks form in the cover or any part of your M-Twist trimmer head, it is time for replacement. (Fig.3)

Be certain that your M-Twist is installed properly before operating. Rotate the head by hand prior to starting the engine to ensure proper installation. An unbalanced head will result in high levels of vibration and possible disengagement from your machine. (Fig.4)

Keep all persons and animals away from your working area—at least 15 meters away. Also, pay close attention to the proximity of parked cars, windows or other objects that can be damaged by flying debris.

Do not operate the M-Twist trimmer head at speed greater than 10,000 RPM.

Avoid contacting solid objects such as concrete, stone and glass bottles while operating your trimmer or brushcutter with the M-Twist head. (Fig 5)

When advancing line with the bumping motion, reduce your operating speed to 4,500 RPM.

If you detect any problems with the head, stop your engine immediately and inspect the cutting attachment. Any failed part or component must be replaced immediately. Failure to do so can result in serious injury.

When you stop your engine to perform any service work on the M-Twist head, make certain rotation has fully ceased

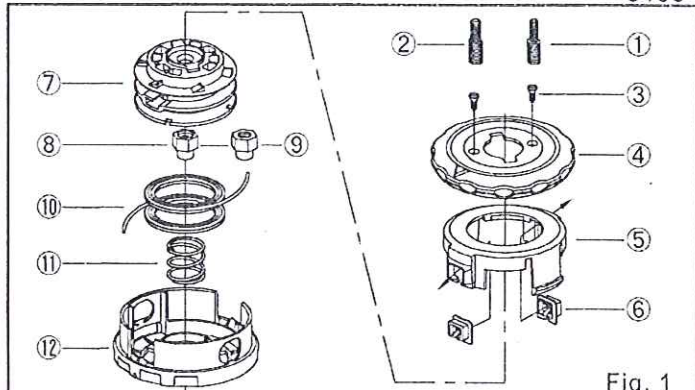

Fig. 1

No.	Part #	DESCRIPTION	Q'ty
①	463755	BOLT M7XM10	1
②	463754	BOLT M8XM10	1
③	463747	TAPPING SCREW	2
④	463753	CASE COVER	Black 1
⑤	463752	CASE	Black 1
⑥	424825	EYELET	2
⑦	463750	LINE HOLDER	Black 1
⑧	463748	NUT M10X1.25	1
⑨	463756	NUT M8X1.25	1
⑩	424828	NYLON CODE	1
⑪	463749	SPRING	1
⑫	463751	COVER	Black 1

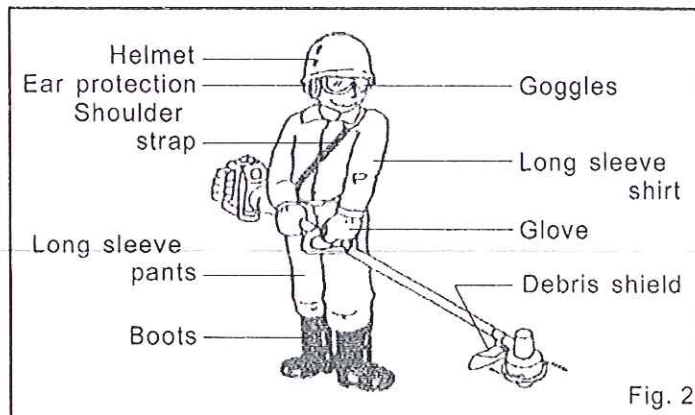

Fig. 2

When the wear mark disappears, or the metal wear-plate is worn down, it is time for replacement.

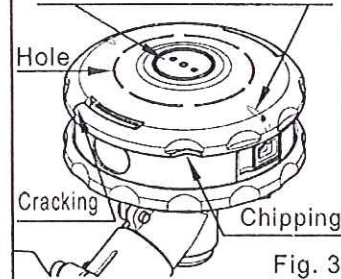
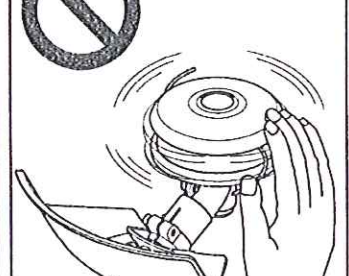

Fig. 3

Check deflection and/or noise.



Rotating the head by hand. Fig. 4



INSTALLATION

CAUTION

- Before starting your engine, be sure to check the installation of the head on your machine by rotating the head by hand.

Bolt and Nut type gearcases (also refer to your equipment manufacturer's operator's manual for information).

1. Place the M-Twist head onto the gearcase of your trimmer or brushcutter. (Fig. 7)
2. Tighten the gearcase's bolt and nut firmly and then lock the driveshaft of your machine. (Fig. 7)

OPERATION

CAUTION

- Do not operate at speeds greater than 10,000 RPM.
- When advancing line, bump the head at a speed slightly less than 4,500 RPM.
- Do not contact solid objects such as stone, concrete, wood or glass bottles.
- Keep all bystanders at a distance of at least 15 meters and pay close attention to the proximity of objects such as parked cars, glass windows, etc.

The M-Twist is a trimmer head that advances line when it is bumped onto the ground during rotation. Normal operation is at 6,000 RPM. Slower operation will reduce cutting efficiency and will cause the line wound inside the head to lose tension. When your cutting line becomes too short, simply bump the head on the ground at approximately 4,500 RPM rotation speed and advance more line.

HOW TO WIND CUTTING LINES

CAUTION

*Stop the engine and make sure that the head is stopped before you do any service on the head.

1. Line up the ▼ mark on the case cover with eyelet. This operation is accomplished easily when the case cover is rotated in the ① direction and returned in the ② direction. (Fig. 8)
2. Cut the nylon line to 1.5 to 3 meters. Insert the line into the eyelet under ▼ mark. (Fig. 9) Adjust the nylon line of both sides to the same length. (Fig. 10)
3. Turn the cover a half-rotation and pull both sides of line to lock it in place. Repeat 2-3 times. (Fig. 11)
4. Wind the top cover until the line is fully wound into the head with only 10-15cm of line protruding from each eyelet. *Do not over-wind or the line will pull inside the eyelet. (Fig. 12 & Fig. 13)

SPECIFICATIONS ARE SUBJECT TO CHANGE WITHOUT NOTICE

 **MARUYAMA MFG. CO., INC.**

4-15 Uchi-kanda 3-Chome, Chiyoda-ku Tokyo

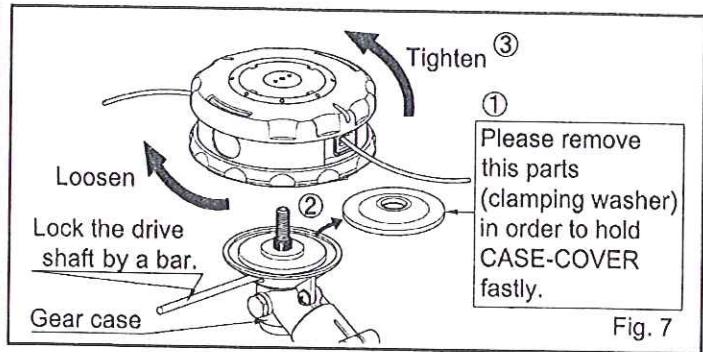

Fig. 7

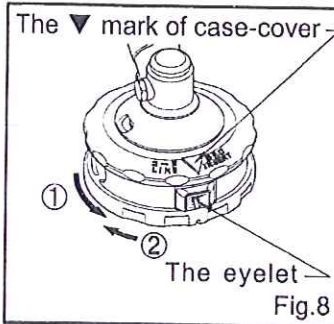

Fig. 8

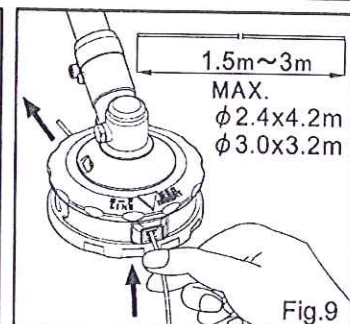

Fig. 9

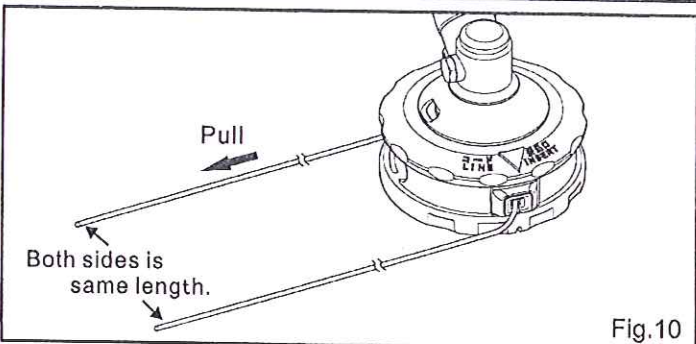

Fig. 10

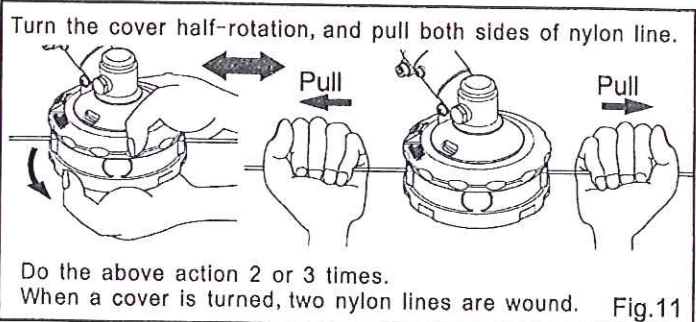

Fig. 11

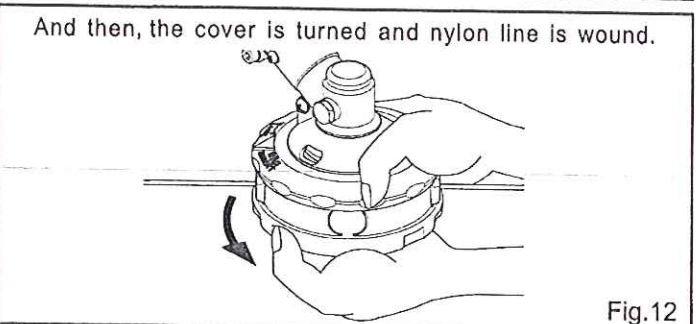
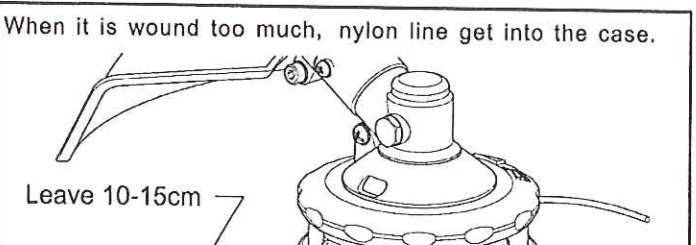

Fig. 12



Model 463743

COVER = 463751

SPRING = 463749



IONS (463757)
M-TWIST
head for use
ushcutters.
Twist

Pp