



MARUYAMA®

OWNER'S/OPERATOR'S MANUAL

NEW THROTTLE TRIGGER CONVERSION KIT

And also watch the instruction video.



The **POWER** in Outdoor Power

Completely read and understand this manual PRIOR to using this product.

CONVERSION KIT INCLUDES

- Throttle cable
- Throttle trigger assembly
- Two compression bands
- Anti-vibration grip
- Plastic corrugated tube
- Metal shaft tool

TOOLS THAT ARE NOT INCLUDED IN THE KIT

- Ruler
- Stop switch wire pulling tool
(make your own using the wire.)
- Hex wrench (4 mm)
- Screwdriver (#2 Phillips head)
- Box cutter knife (if necessary, it uses in order to remove the old grip.)
- A pair of cut resistant gloves
- Glass of water.

BEFORE ATTACHING

First, remove the old throttle trigger assembly and the old grip.

NEW THROTTLE TRIGGER INSTALLING

Take a 4 mm hex wrench and loosen the socket head cap screw on the new throttle trigger assembly.

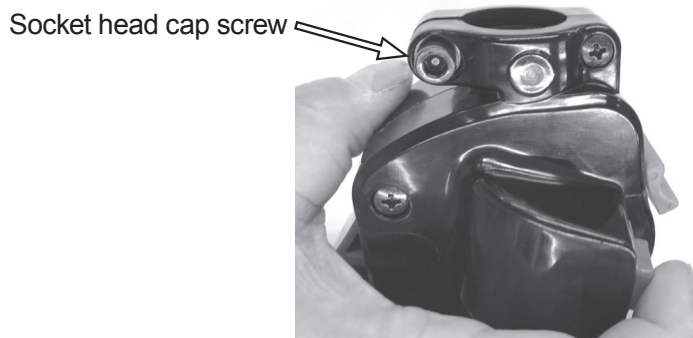

Set the control lever to the “L” position on the new throttle trigger assembly.

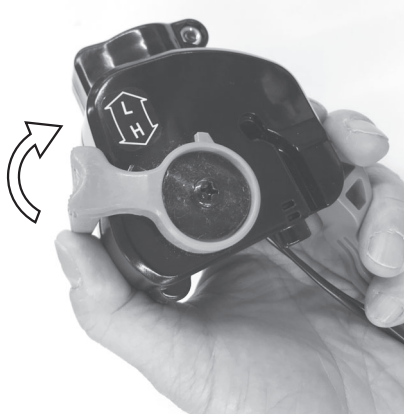

Make sure to align the new throttle trigger assembly so that it matches the loop handle and the gearcase.

Once the new throttle trigger is properly aligned tighten the socket head cap screw.



ANTI VIBRATION GRIP INSTALLING

Slide one of the compression band onto the shaft assembly.

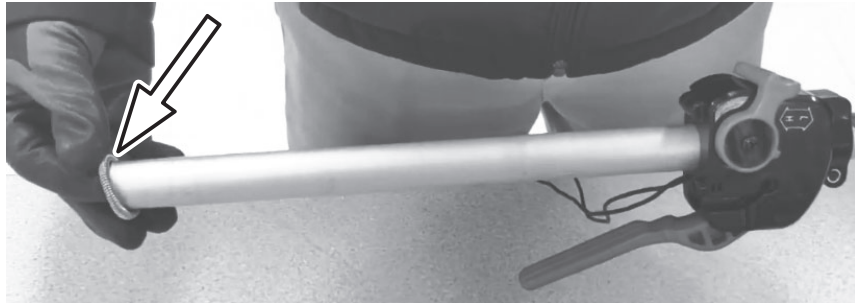

Put some water on the inside of the grip and onto the shaft assembly for easy installation. Do not use any oil or other lubricants for this operation. Only the use of water is possible.

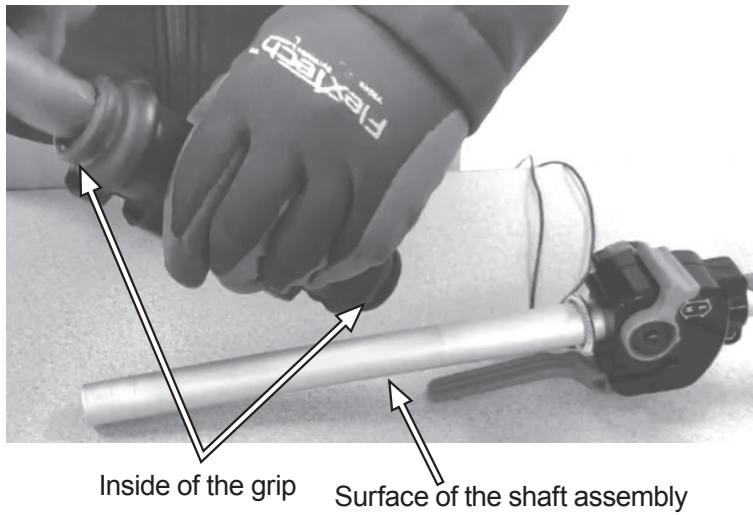

Inside of the grip Surface of the shaft assembly

Pay attention to the direction of the grip while installing.
Make sure the looped side faces the trigger side.

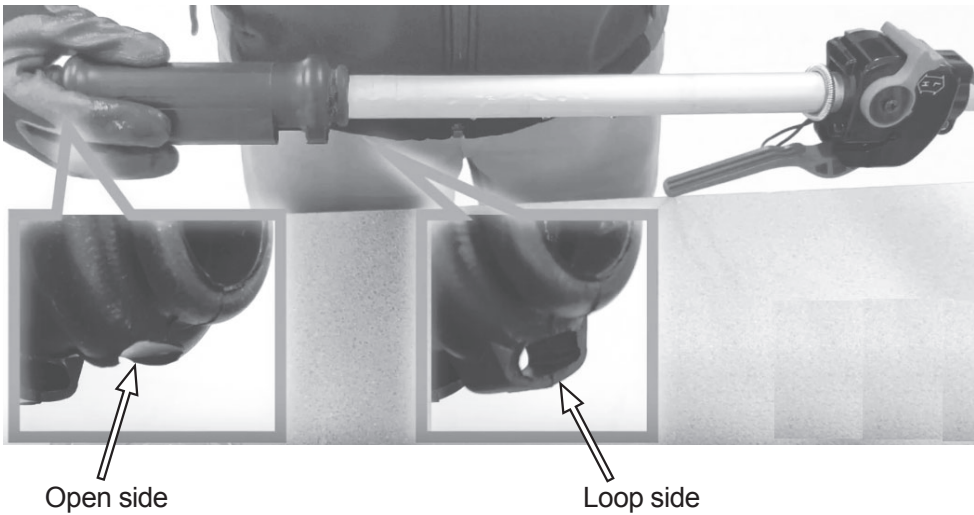

Open side Loop side

Locate the grip to make a space between the grip and the end of the driveshaft tube. The position is according to the table below.

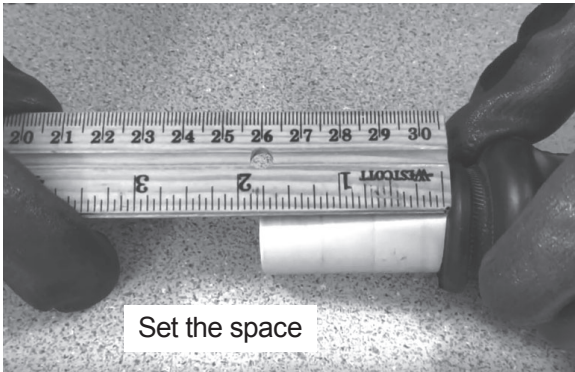

| Model | | inches | mm |
|---------------------------------|------------|--------|----|
| BT23L (includes rubber cushion) | | 2.7 | 68 |
| E27 | EH23DSL | 2.6 | 65 |
| BM24 | B30L TURBO | 1.4 | 35 |
| B23L | M27QC | | |
| EH23D | M30QC | | |
| B27L | E30S | | |
| B27L TURBO | EH27D-S | | |
| B30L | | | |

Align the grip so that the loop of the grip and the cable receiver of the throttle trigger assembly are matched.

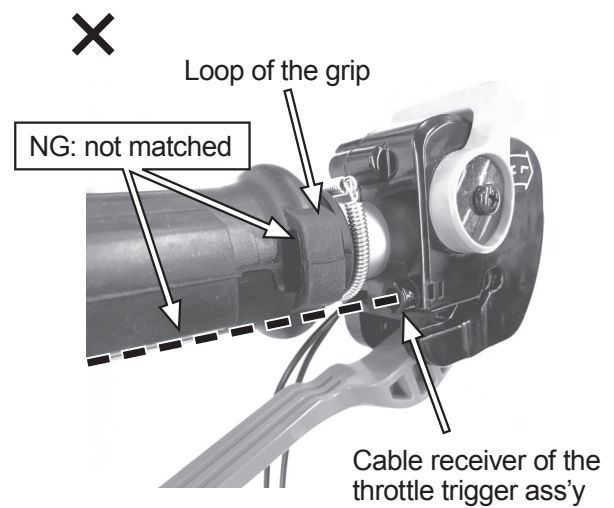
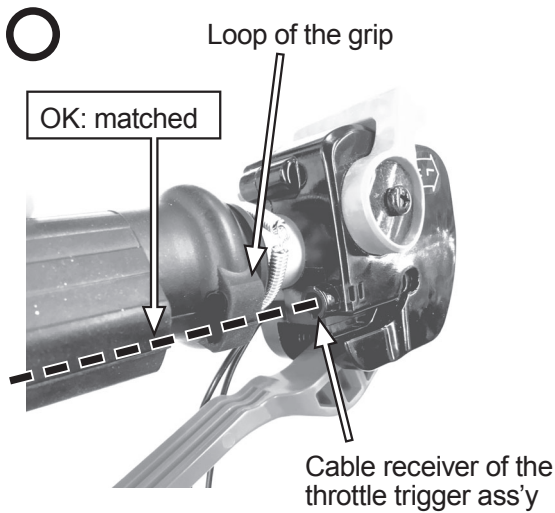

After alignment fit the grip with two compression bands.

Use the metal shaft tool and insert it up under the compression band while working it around the lip of the grip.

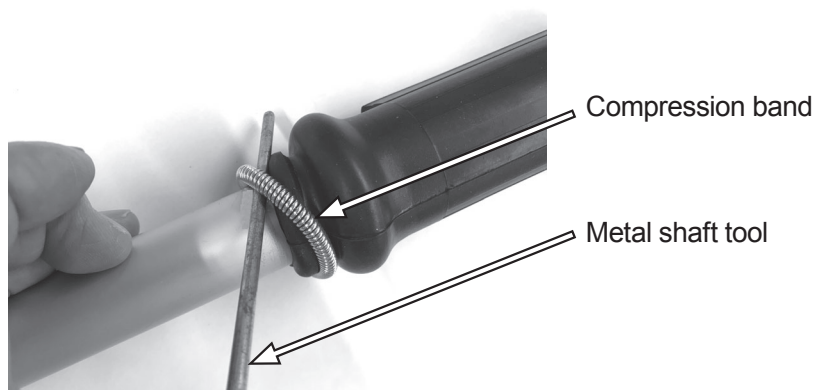

Repeat the same operation for the other band.

THROTTLE CABLE AND STOP SWITCH WIRES INSTALLING

Take a wire pulling tool and insert it into the narrow underside of the grip. Take the stop switch wires loop them in the middle and insert the hook of the pulling wire pulling tool. Pull the wire tool towards the back end of the grip.

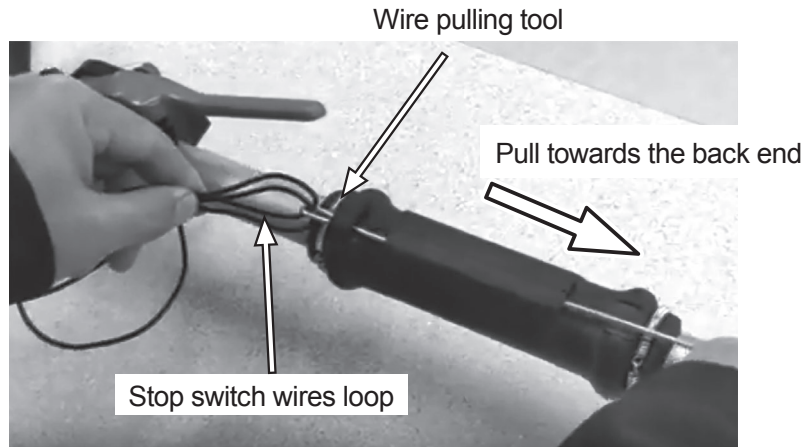

With the control lever on the "L" position, insert the throttle cable through the underside of the grip and install it on to the throttle trigger assembly.

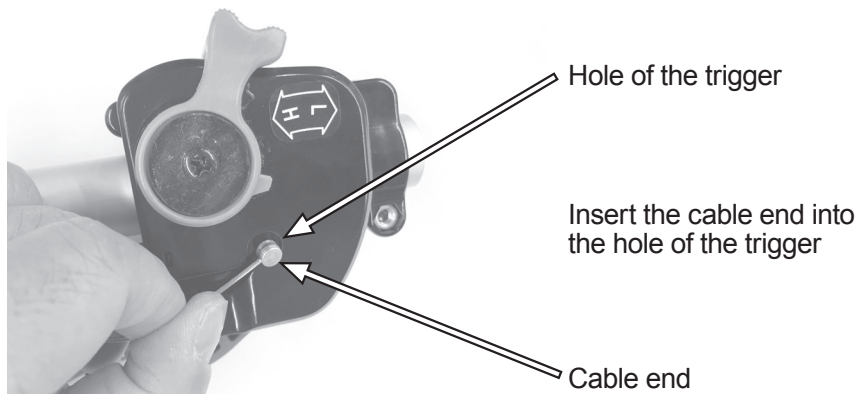
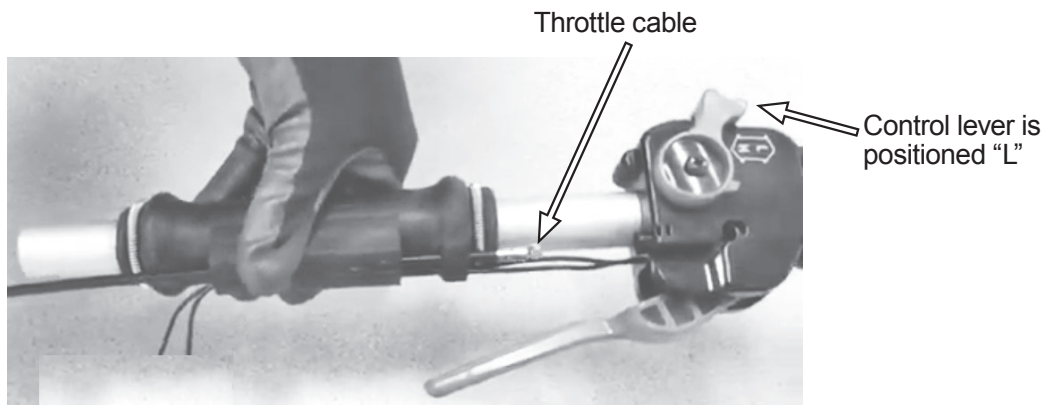

Insert the cable end as far as it will go with metal shaft tool.
And insert the inner cable firmly into the groove of the trigger.

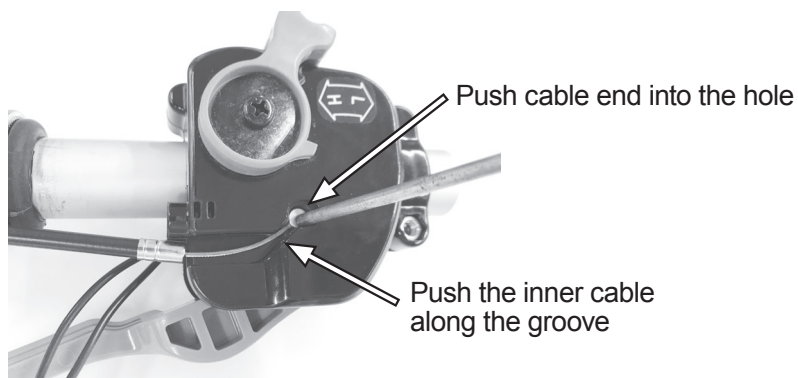

Push the cable housing end into the cable receiver of the throttle assembly.

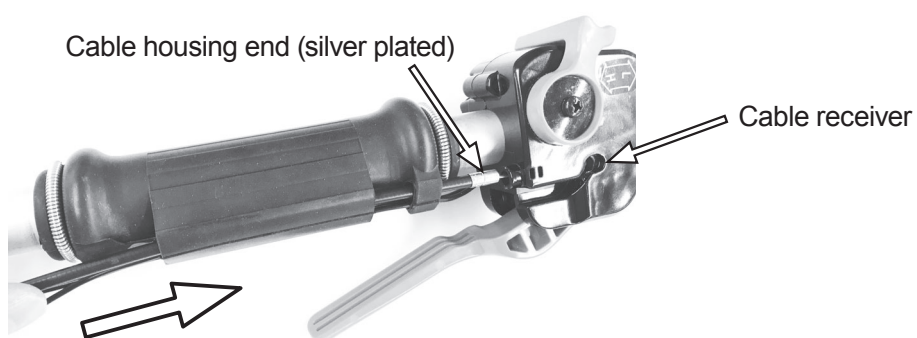

Push the throttle trigger assembly towards the grip while pulling the stop switch wires.

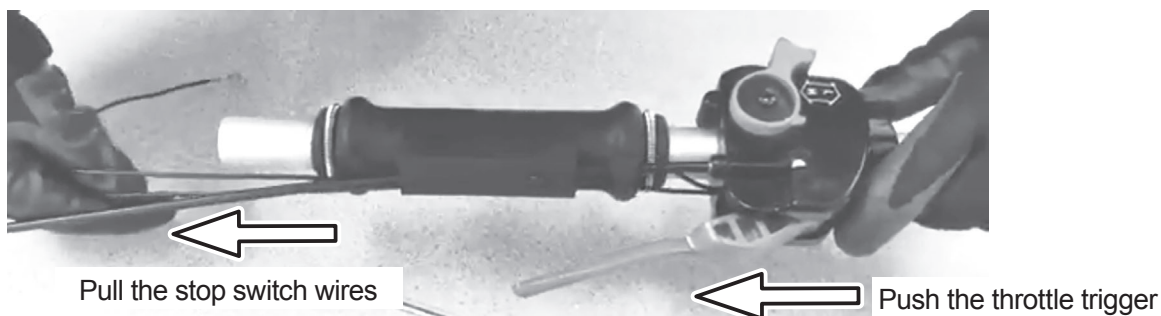

Then tighten the socket head cap screw on the throttle assembly.



Install the plastic corrugated tube around the throttle cable and stop switch wires.

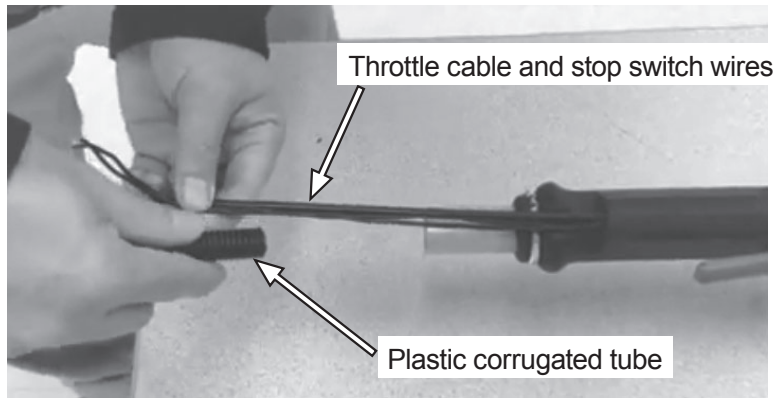

ENGINE AND DRIVISHAFT REINSTALLING

Install the engine back onto the drive shaft assembly.
Turn the engine to mesh the gearcase and the driveshaft.

Push while turning the engine.

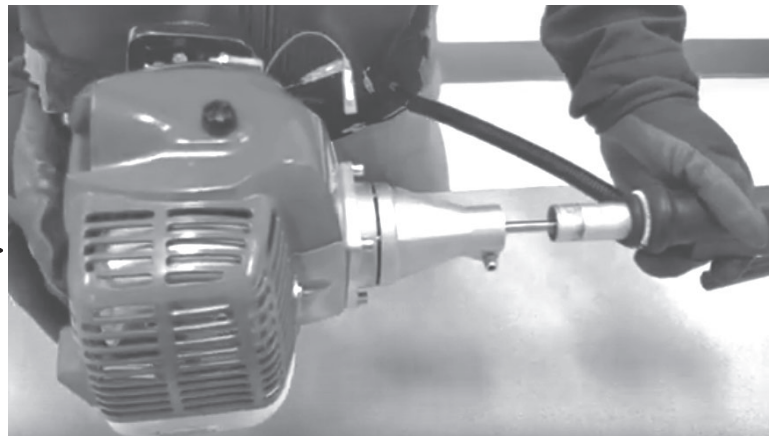
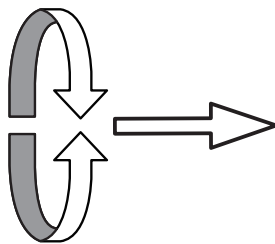

Make sure that there is a space between the grip and the clutch case assembly. See table for correct space. If the space is larger than the correct value, driveshaft is not meshed with the gearcase. If the space is incorrect, start over from page US-3.

After checking, tighten the socket head cap screw on the side of the clutch case assembly.

Socket head screw



Check the space

| Model | | inches | mm |
|------------|------------|--------|----|
| BT23L | | 0.6 | 15 |
| E27 | EH23DSL | 1.2 | 30 |
| BM24 | B30L TURBO | 0.2 | 5 |
| B23L | M27QC | | |
| EH23D | M30QC | | |
| B27L | E30S | | |
| B27L TURBO | EH27D-S | | |
| B30L | | | |

ATTACHING THROTTLE CABLE

Attach the throttle cable to the throttle slotted fitting.

1. Position the slotted fitting on the carburetor so the recessed hole for the lug is away from the cable adjuster sleeve.
2. Rotate the carburetor throttle cam and slip the throttle cable through the slot in the slotted fitting, making sure the cable lug drops into the recessed hole.

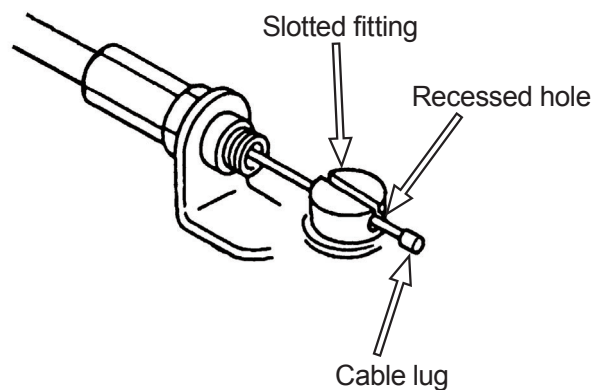
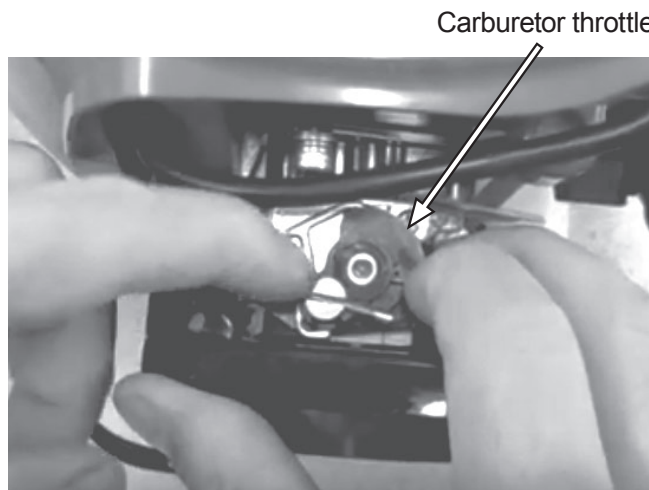

Install the stop switch wires into the matching connectors from the engine. And bind the connectors by clamp.

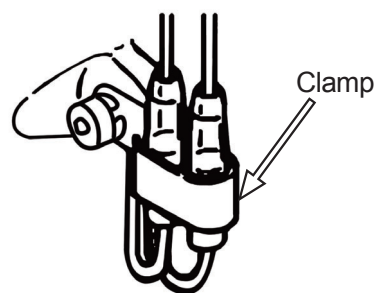

FUNCTIONAL TESTING

The L position of the control lever indicates low throttle and the throttle cable will not actuate fully. Pull the throttle lever fully while set the control lever to the H position and test the functionality of the throttle trigger.

The throttle should actuate if installed correctly.

Check both position L and H.

Position H (Carburetor throttle cam fully turned!)

Control lever is fully turned to H position

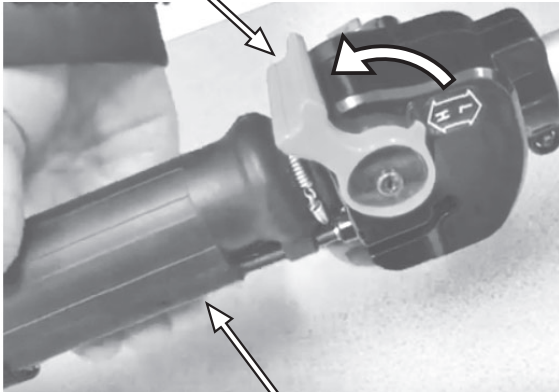

And also throttle lever is fully grasped

Carburetor throttle cam fully turned

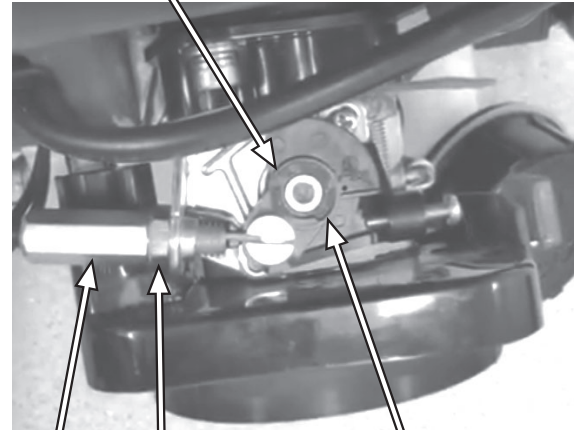

Cable adjuster sleeve

Lock nut

Carburetor throttle cam

Position L:

Carburetor throttle cam and idle adjustment screw make sure to contact!

Control lever is fully turned to L position

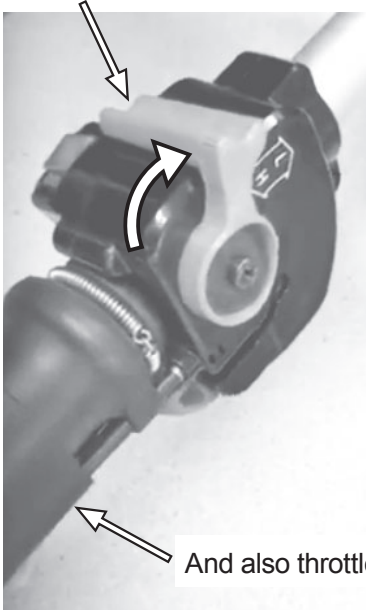

And also throttle lever is fully grasped

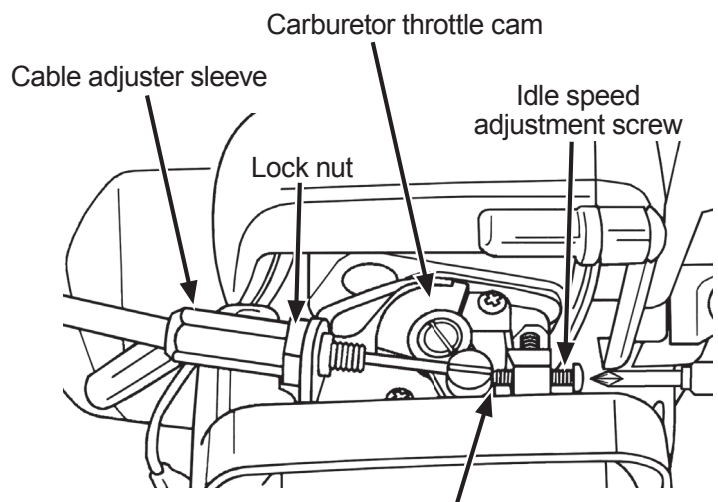

Carburetor throttle cam and idle adjustment screw make sure to contact!

Reinstall the air filter cover. Conversion work is completed.

INSTRUCTION OF THE THROTTLE TRIGGER

Start the cutting attachment rotation

1. Grasp the throttle lever.
2. Move the control lever to high speed side slowly.
3. Then engine speed increase gradually, and the cutting attachment starts rotation.
4. Adjust the cutting attachment rotational speed by the control lever.

Note: Engine speed does not increase by grasping the throttle lever. If the control lever is positioned at low speed side fully.

Stop the blade rotation

1. The engine speed will down to idling by moving the control lever to low speed position fully, or releasing the throttle lever.
2. If you did not change the control lever position, engine speed become to the original adjusted speed when grasp the throttle lever again.

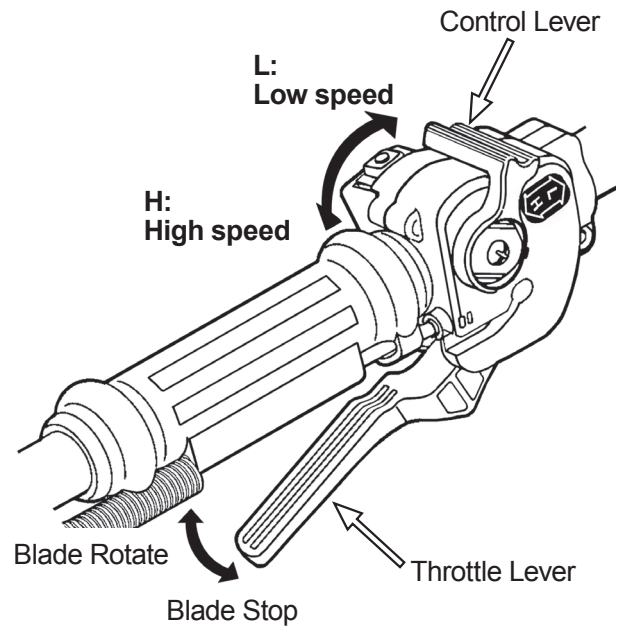



Maruyama U.S., Inc.

4770 Mercantile Drive,
suite100,

Fort Worth, TX 76137 U.S.A.

Phone 940-383-7400

Fax 940-383-7466

www.maruyama-us.com

P/N 242592-00 US 20.03 IN