



MARUYAMA®

OWNER'S/OPERATOR'S MANUAL

HANDLEBAR HANDEL KIT

CONVERSION KIT INCLUDES

- Handlebar comp. for left hand
- Handlebar comp. with throttle trigger for right hand
- Clamp bracket Ass'y
- Shoulder strap
- Hanging bracket ass'y
- Debris shield
- Debris shield bracket ass'y
- Socket button head cap screw (M5×10)
- Blade cover (one pair)
- Boss adopter
- Clamping washer
- Stabilizer
- Blade bolt (M8/ Left hand thread)
- Box spanner
- Hex wrench (3 mm)
- Hex wrench (4 mm)
- Hex wrench (5 mm)
- Band (short)
- Band (long)
- This instruction manual

TOOLS THAT ARE NOT INCLUDED IN THE KIT

- Ruler
- Box cutter knife
(in order to cut open the shaft grip)
- A pair of cut resistant gloves

BEFORE ATTACHING

First, remove the old throttle trigger assembly, throttle cable and stop switch wires.

CLAMP BRACKET ASS'Y AND HANGING BRACKET ASS'Y INSTALLING

Attach the clamp bracket and the hanging bracket on the shaft assembly. Attach it in the best position by referring to the following dimensions.

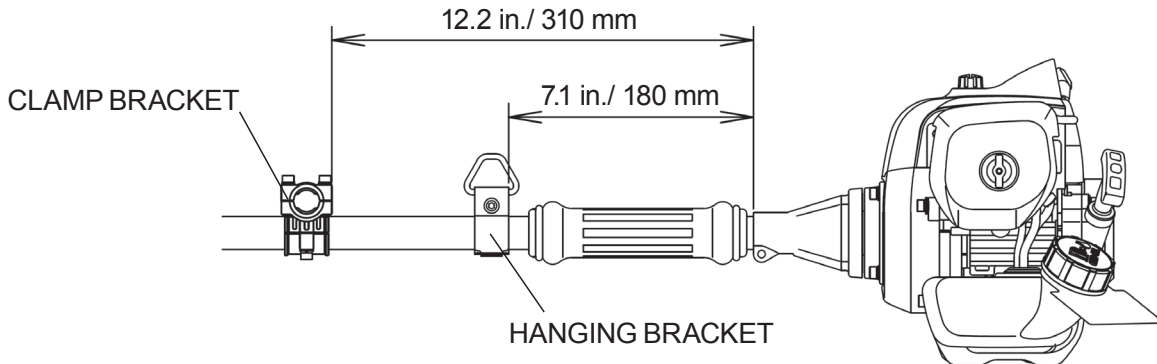

HANDLEBAR INSTALLATION

IMPORTANT: Be careful not to damage the throttle cable and stop switch wires when you remove the handlebars from the kit carton.

1. Loosen the four screws on the top of the clamp bracket.
2. Insert the left and right handlebars into the clamp bracket. **Note that the handlebar with the throttle trigger and stop switch go on the right-hand side of the Trimmer/Brushcutter.**
3. Adjust the handlebar to the desired position, then tighten the four screws.

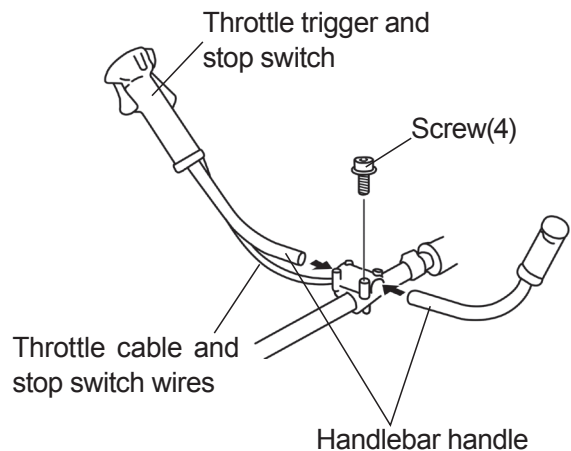

WIRE ASS'Y INSTALLATION

1. Cut open the longer tunnel of the grip with box cutter. **Note that never cut the shorter tunnel.**

Longer tunnel
Shorter tunnel
Never cut!



2. Thread the wire assembly through the short tunnel, and push into the longer tunnel cut opened. Bind the wire assembly with the longer band as shown.

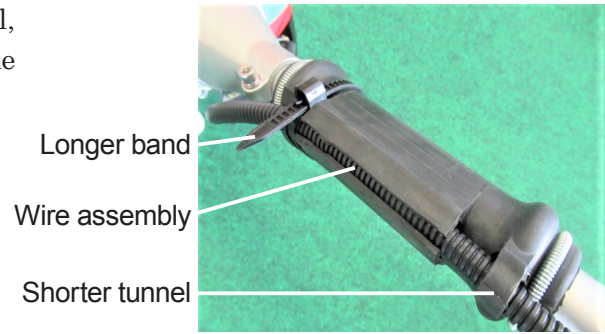

3. Bind the wire assembly with shorter band as shown.



4. First, unscrew the locking nut and remove the cable adjuster sleeve.

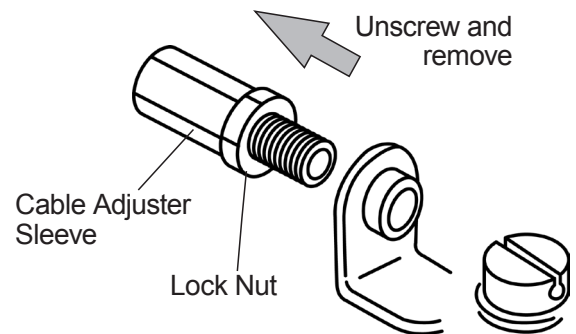

5. Insert the throttle cable through the carburetor bracket, then screw a cable adjuster sleeve into the carburetor bracket fully.

6. Position the slotted fitting on the carburetor so the recessed hole for the lug is away from the cable adjuster sleeve.

7. Rotate the carburetor throttle cam and slip the throttle cable through the slot in the slotted fitting, making sure the cable lug drops into the recessed hole.

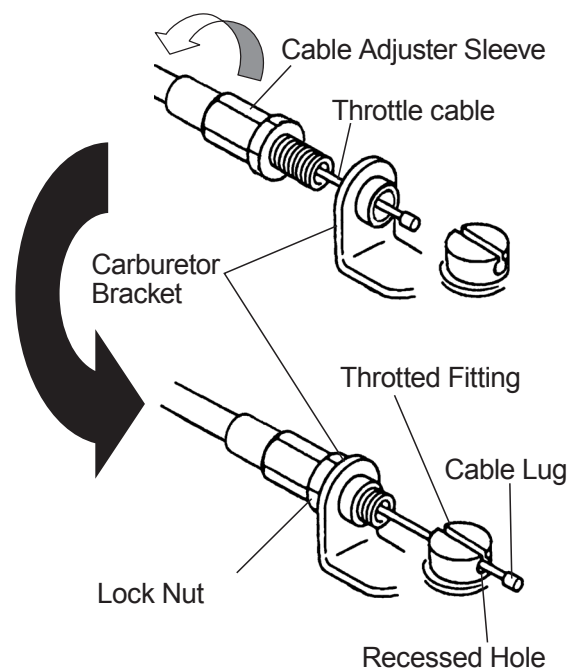

8. Operate the throttle trigger a few times to make sure that it works correctly.

9. Adjust the cable adjuster sleeve so the stop on the carburetor throttle cam just contacts the throttle stop and the cable position keep 1-2mm play between cable lug and slotted fittings when the throttle trigger is fully depressed.

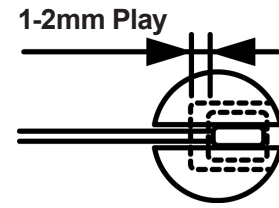

10. When the throttle cable is adjusted correctly, tighten the locknut.

11. Plug the stop switch wires into the matching connectors from the engine.

Note that the wire polarity is not important.

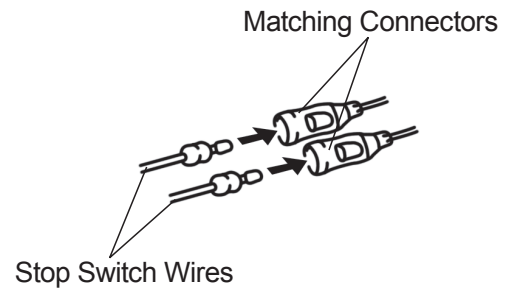

12. Bind the stop switch wires with the clamp.

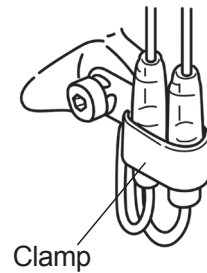

DEBRIS SHIELD REPLACEMENT

1. Remove the current debris shield. And remove the M5 × 12 socket head screw and the clamp.

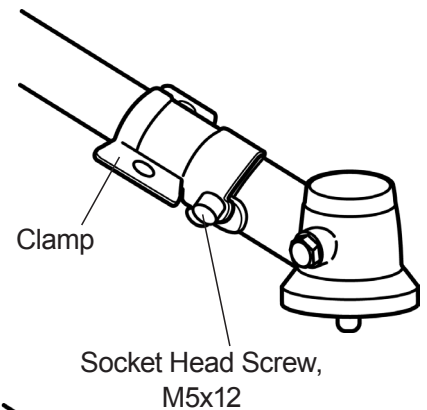

2. Tighten the M5 × 10 socket head screw included in the kit. In other words, replace the screw on the gearcase with the screw in the kit.

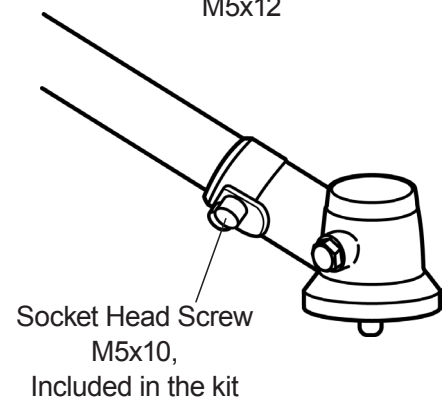

- Attach the new debris shield to the gearcase with the two M6 × 30 screws as shown.

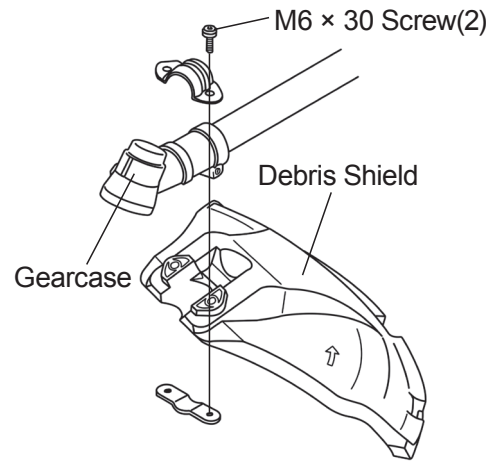

INSTALLING BRUSH CUTTER BLADE

⚠ WARNING

POTENTIAL HAZARD

- If the Brushcutter blade is not adequately tightened, it can come loose from the Brushcutter during use.

WHAT CAN HAPPEN

- This may cause damage to property or personal injury.

HOW TO AVOID THE HAZARD

- Make sure the Brushcutter blade is securely fastened to the attaching shaft in the gearcase.

⚠ CAUTION

POTENTIAL HAZARD

- Brushcutter blade is sharp.

WHAT CAN HAPPEN

- Contact with sharp blade can cause serious personal injury.

HOW TO AVOID THE HAZARD

- Wear gloves when you handle the blade.

- Remove the current trimmer head and the aluminum boss adapter from the attaching shaft out of the gearcase.

Note: The trimmer head has left-hand thread.

- Install the steel boss adapter included in the kit on to the attaching shaft.
 - Install the brushcutter blade onto the boss adapter, then install the clamping washer, the stabilizer and the blade bolt. The clamping washer, the stabilizer and the blade bolt are included in the kit.
 - Align the hole in the boss adapter with the guide slot in the gearcase.
 - Insert the 3mm hex wrench into the hole in the boss adapter and the guide slot in the gearcase to lock the attaching shaft.
 - Tighten the blade bolt.
- Note: The blade bolt has left-hand thread.**
- Remove the 3mm hex wrench from the boss adapter and gearcase.

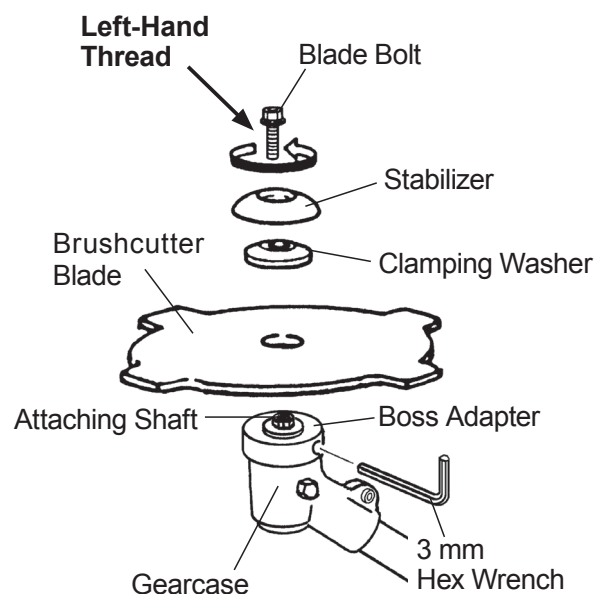

ATTACHING STRAP

⚠ WARNING

POTENTIAL HAZARD

- Without the strap installed on the Brushcutter, the blade can produce side thrust which can expose the operator and bystanders to blade contact.

WHAT CAN HAPPEN

- Contact with the Brushcutter blade can cause personal injury.

HOW TO AVOID THE HAZARD

- Never operate the Brushcutter without installing and using the strap.

Snap the strap hook into the ring on the shaft assembly.

To detach the strap quickly from the Brushcutter, pull upward on the red band.

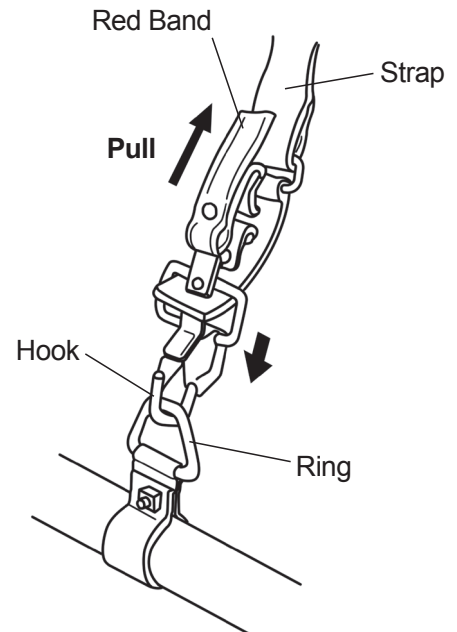

BRUSHCUTTER OPERATING POSITION **[Handlebar Handle Models]**

Before using the Brushcutter, check the following:

1. Make sure the 3mm hex wrench has been removed from the gearcase and boss adapter before you start the engine.
2. The operator must be wearing the strap attached to the Brushcutter, and the Brushcutter must be on the operator's right side.

⚠ WARNING

POTENTIAL HAZARD

- Without the strap installed, the Brushcutter blade can produce side thrust which can expose the operator and bystanders to blade contact.
- If the Brushcutter is not correctly positioned on the operator's right side, the blade can produce side thrust which can expose the operator and bystanders to blade contact.

WHAT CAN HAPPEN

- Contact with the Brushcutter blade can cause severe personal injury.

HOW TO AVOID THE HAZARD

- Never operate the Brushcutter without installing and using the strap.
- Always operate the Brushcutter with the unit on your right side.

3. The operator's right hand should be holding the right-hand throttle grip, with his or her fingers on the throttle trigger.
4. The left hand should be holding the left-hand grip with the fingers and thumb fully enclosed around the grip.
5. Accelerate and hold the engine at cutting speed before entering the material to be cut.
6. Always release the throttle trigger and allow the engine to return to idle speed when not cutting.
7. Stop the Brushcutter engine when moving between work sites.

⚠ CAUTION

- Always wear gloves and protective clothing when operating the Trimmer/Brushcutter.

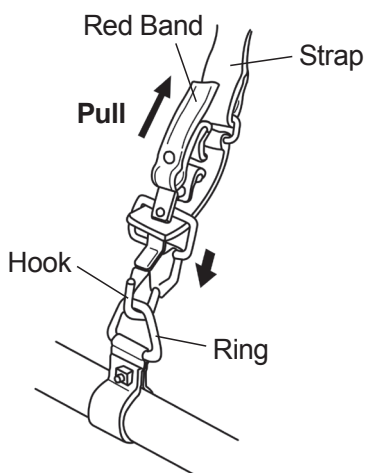

- If the Brushcutter blade becomes jammed, stop the engine immediately.
- Make certain all moving parts have stopped and disconnect the spark plug before inspecting the equipment for damage.
- Never use a Brushcutter that has chipped, cracked or broken cutting attachment or shield.

IMPORTANT: To detach the strap quickly from the Brushcutter, pull upward on the red band.

CUTTING DIRECTION

⚠ WARNING

POTENTIAL HAZARD

- Cutting heavy brush or small trees from the wrong direction can cause the Brushcutter blade to kick back.

WHAT CAN HAPPEN

- Contact move the Brushcutter blade can cause severe personal injury.

HOW TO AVOID THE HAZARD

- Always move the Brushcutter from right to left when cutting heavy brush or small trees as shown.

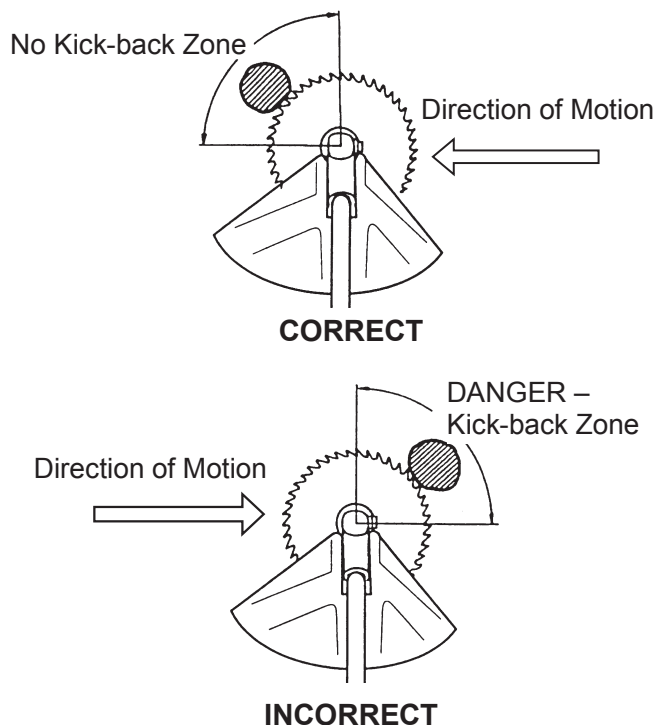

When cutting heavy brush or small trees, always move the Brushcutter from right to left. Moving the Brushcutter from left to right can cause the blade to kick back.

CUTTING BLADES

1. Use only the correct blade (MARUYAMA genuine part) approved for the application and model Brushcutter.
2. Carefully check the condition of the blades before and after operation.
3. Sharpen dull blades. Replace any blade that is worn, cracked or damaged.
4. If a blade produces eccentric rotation or vibration, replace the blade and the boss adapter with genuine MARUYAMA parts.



Maruyama U.S., Inc.

4770 Mercantile Drive,
suite100,

Fort Worth, TX 76137 U.S.A.

Phone 940-383-7400

Fax 940-383-7466

www.maruyama-us.com

P/N 242589-00 US 20.08 IN