

OPERATOR'S MANUAL

MANUAL DEL OPERADOR / MANUEL D'OPÉRATEUR

String Trimmer / Recortadora / Coupe-bordures
B23L, B27L TURBO, B30L, B30L TURBO

Brush Cutter / Desbrozadora / Débrossailleur
B23, B30

(Shown with Bullhorn Handle Kit Installed)
(Mostrado con el kit empuñaduras Bullhorn instalado)
(Illustré avec le kit poignées Bullhorn installé)

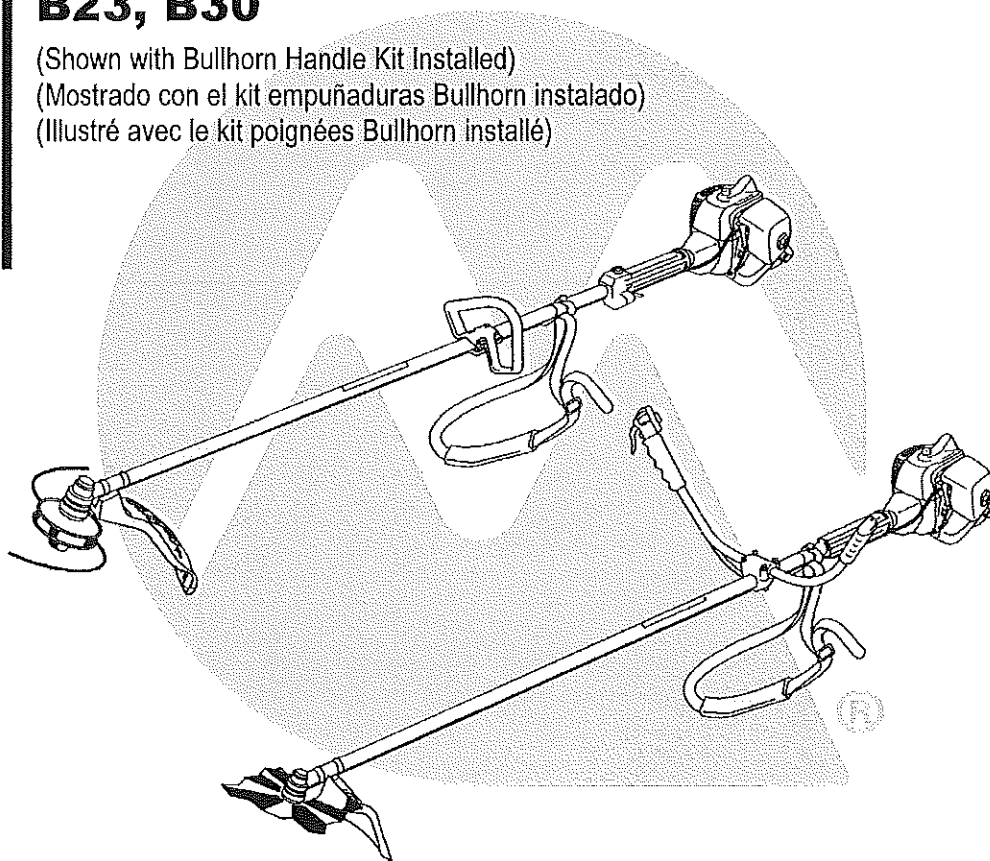

3570 SHELBY LANE • DENTON, TX 76207 • PH: 940.383.7400 • FAX: 940.383.7466

www.maruyama.com

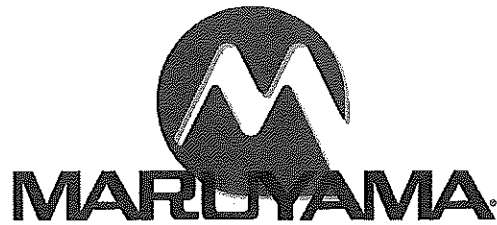

Limited Warranty Statement

All Maruyama commercial/ industrial products are warranted to the original purchaser to be free from defects in material and workmanship **from the date of purchase** for the time periods listed as follows:

Lifetime for inner drive shaft on trimmers and brushcutters and all ignition modules.

3 years for residential, non-institutional, non-income producing use.

1 year for industrial, commercial, institutional, rental and income producing use.

Maruyama AE series engines and Kawasaki TEX45/TEX54 are covered exclusively for one additional year of industrial, commercial, institutional, rental and income producing use (total of 2 years).

All other engines refer to engine manufacturer's warranty statement.

Any part of a Maruyama product found to be defective within the applicable warranty period shall, at Maruyama's option, be repaired or replaced without charge. Warranty consideration is obtained by delivering any Maruyama product believed to be defective to an Authorized Maruyama Servicing Dealer within the applicable warranty period.

The purchaser shall not be charged for diagnostic labor that leads to the determination that a warranted part is defective, if the diagnostic work is performed at a Maruyama Dealer.

Any warranted part which is not scheduled for replacement as required maintenance, or which is scheduled only for regular inspection to the effect of "repair or replace as necessary" shall be warranted for the warranty period. Any warranted part, which is scheduled for replacement as, required maintenance shall be warranted for the period of time up to the first scheduled replacement point for that part. Maruyama Mfg. Co., Inc. is liable for damages to other engine components caused by the failure of a warranted part still under warranty.

The purchaser is responsible for the performance of the required maintenance, as defined by Maruyama Mfg. Co., Inc. in the Owner's/Operator's Manual.

EMISSION-RELATED PARTS WARRANTY: In addition to the above warranty coverage, Maruyama Mfg. Co., Inc. will repair or replace, free of charge, for the original purchaser and each subsequent purchaser any emission-related part or parts found to be defective in material and workmanship for two (2) years from original retail delivery date. **Emission-related parts are the carburetor assembly, the ignition coil assembly, the ignition rotor, the spark plug, the catalytic converter and the fuel tank.** Any replacement part that is equivalent in performance and durability may be used in non-warranty maintenance or repairs, and shall not reduce the warranty obligations of Maruyama Mfg. Co., Inc.

This warranty does not cover the following:

1. Maintenance items (excluding defects in materials and workmanship) including hoses, spark plugs, starter rope, air and fuel filters, clutch shoes, vibration isolators, throttle cables and all cutting attachments, etc.
2. Extra expenses including shipping and handling, travel, payment for lost time or pay and for any inconvenience and storage.
3. Alterations or modifications including aftermarket parts not authorized by Maruyama U.S., Inc.
4. Wear, accident, abuse, neglect, misuse, negligence, improper fuels, lubricants, fuel mixtures (when applicable), or failure to operate or maintain the product in accordance with instructions approved by Maruyama.

Repair or replacement as provided under this warranty is the exclusive remedy of the consumer. Maruyama shall not be liable for any incidental or consequential damages for breach of any express or implied warranty on these products except to the extent prohibited by applicable law. Any implied warranty of merchantability or fitness for a particular purpose on these products is limited in duration to the warranty period as defined in the limited warranty statement. Maruyama reserves the rights to change or improve the design of the product without notice and does not assume obligation to update previously manufactured products.

This warranty provides you with specific legal rights, which may vary from state to state.

It is the Owner's and Dealer's responsibility to make sure the Warranty Registration Card is properly filled out and mailed to Maruyama U.S., Inc. Proof of purchase and registration will be required in order to obtain warranty service.

To locate an Authorized Maruyama Servicing Dealer nearest you, contact:

Maruyama U.S., Inc.
3570 Shelby Lane
Denton, TX 76207
(940) 383-7400
maruyama@maruyama-us.com
www.maruyama-us.com

⚠ WARNING: ⚠
 The engine exhaust from this product contains chemicals known to the State of California to cause cancer, birth defects or other reproductive harm.

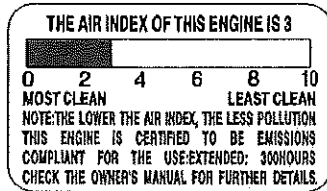

B23L/B23

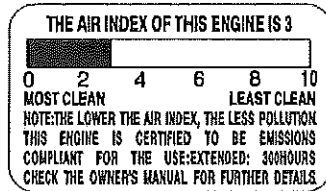

B27L Turbo

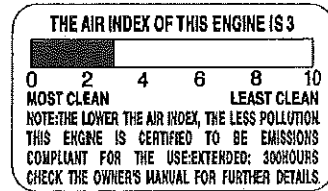

B30L/B30L TURBO/B30

FEDERAL EMISSION CONTROL WARRANTY STATEMENT YOUR WARRANTY RIGHTS AND OBLIGATIONS

The U.S. Environmental Protection Agency (EPA), and Maruyama Manufacturing Company, Inc. are pleased to explain the **emission control system warranty** on your small off-road engine. New 1997 and later model year small off-road engines must be designed, built and equipped, at the time of sale, to meet the U.S. EPA regulations for small off-road engines. The equipment engine must be free from defects in materials and workmanship which cause it to fail to conform with U.S. EPA standards for the first two years of engine use from the date of sale to the ultimate purchaser. Maruyama Manufacturing Company, Inc. must warrant the emission control system on your small off-road engine for the period of time listed above provided there has been no abuse, neglect or improper maintenance of your small off-road engine.

Emission durability of 300 hours.

Your emission control system may include parts such as the carburetor or fuel injection system, the ignition system, and catalytic converter. Also included may be hoses, belts, and connectors and other emission related assemblies.

Where a warrantable condition exists, Maruyama Manufacturing Company, Inc. will repair your small off-road engine at no cost to you, including diagnosis (if the diagnostic work is performed at an authorized dealer), parts, and labor.

MANUFACTURER'S WARRANTY COVERAGE:

The 1997 and later model year small off-road engines are warranted for two years. If any emission-related part on your engine is defective, the part will be repaired or replaced by Maruyama Manufacturing Company, Inc. free of charge.

OWNER'S WARRANTY RESPONSIBILITIES:

(a) As the small off-road engine owner, you are responsible for the performance of the required maintenance listed in your owner's manual.

Maruyama Manufacturing Company, Inc. recommends that you retain all receipts covering maintenance on your small off-road engine, but Maruyama Manufacturing Company, Inc. cannot deny warranty solely for the lack of receipts or for your failure to ensure the performance of all scheduled maintenance. Any replacement part or service that is equivalent in performance and durability may be used in non-warranty maintenance or repairs, and shall not reduce the warranty obligations of the engine manufacturer.

- (b) As the small off-road engine owner, you should be aware, however, that Maruyama Manufacturing Company may deny you warranty coverage if your small off-road engine or a part has failed due to abuse, neglect, improper maintenance or unapproved modifications.
- (c) You are responsible for presenting your small off-road engine to a Maruyama Manufacturing Company, Inc. service center as soon as a problem exists. The warranty repairs should be completed in a reasonable amount of time, not to exceed 30 days.

If you have any questions regarding your warranty rights and responsibilities, you should contact Maruyama U.S., Inc. at **1-866-783-7400**.

COVERAGE

Maruyama Manufacturing Company, Inc. warrants to the ultimate purchaser and each subsequent purchaser that your small off-road engine will be designed, built and equipped, at the time of sale, to meet all applicable regulations. Maruyama Manufacturing Company, Inc. also warrants to the initial purchaser and each subsequent purchaser that your small off-road engine is free from defects in materials and workmanship which cause the engine to fail to conform with applicable regulations for a period of two years.

The 1997 and later model years, EPA requires manufacturers to small off-road engines for two years. These warranty periods will begin on the date the small off-road engine is purchased by the initial purchaser. If any emission-related part on your engine is defective, the part will be replaced by Maruyama Manufacturing Company, Inc. at no cost to the owner.

Maruyama Manufacturing Company, Inc. shall remedy warranty defects at any authorized Maruyama Manufacturing Company, Inc. engine dealer or warranty station. Any authorized work done at an authorized dealer or warranty station shall be free of charge to the owner if such work determines that a warranted part is defective. Any manufacturer-approved or equivalent replacement part may be used for any warranty maintenance or repairs on emission-related parts, and must be provided free of charge to the owner if the part is still under warranty, Maruyama Manufacturing Company, Inc. is liable for damages to other engine components caused by the failure of a warranted part still under warranty.

EPA considers emission-related warranted parts to include all the parts listed below. These warranted parts are: **the carburetor assembly, the ignition coil assembly, the ignition rotor, the spark plug, the catalytic converter, and the fuel tank.**

MAINTENANCE REQUIREMENTS

The owner is responsible for the performance of the required maintenance as defined by the Maruyama Manufacturing Company, Inc. in the owner's manual.

LIMITATIONS

This Emission Control System Warranty shall not cover any of the following:

- (a) repair or replacement required because of misuse or neglect, lack of required maintenance, repairs improperly performed or replacements not conforming to Maruyama Manufacturing Company, Inc. specifications that adversely affect performance and/or durability, and alterations or modifications not recommended or approved in writing by Maruyama Manufacturing Company, Inc., and
- (b) replacement of parts and other services and adjustments necessary for required maintenance at and after the first scheduled replacement point.

CALIFORNIA EMISSION CONTROL WARRANTY STATEMENT YOUR WARRANTY RIGHTS AND OBLIGATIONS

The California Air Resources Board (CARB), and Maruyama Manufacturing Company, Inc. are pleased to explain the emission control system warranty on your 2011 and later small off-road engine. In California, new small off-road engines must be designed, built and equipped to meet the State's stringent anti-smog standards. Maruyama Manufacturing Company, Inc. must warrant the emission control system on your small off-road engine for the period of time listed above provided there has been no abuse, neglect or improper maintenance of your small off-road engine.

Your emission control system may include parts such as the carburetor or fuel injection system, the ignition system, and catalytic converter. Also included may be hoses, belts, and connectors and other emission related assemblies.

Where a warrantable condition exists, Maruyama Manufacturing Company, Inc. will repair your small off-road engine at no cost to you, including diagnosis, parts, and labor.

MANUFACTURER'S WARRANTY COVERAGE:

The 1995 and later small off-road engines are warranted for two years. If any emission-related part on your engine is defective, the part will be repaired or replaced by Maruyama Manufacturing Company, Inc.

OWNER'S WARRANTY RESPONSIBILITIES:

- (a) As the small off-road engine owner, you are responsible for the performance of the required maintenance listed in your owner's manual.
Maruyama Manufacturing Company, Inc. recommends that you retain all receipts covering maintenance on your small off-road engine, but Maruyama Manufacturing Company, Inc. cannot deny warranty solely for the lack of receipts or for your failure to ensure the performance of all scheduled maintenance
- (b) As the small off-road engine owner, you should be aware, however, that Maruyama Manufacturing Company may deny you warranty coverage if your small off-road engine or a part has failed due to abuse, neglect, improper maintenance or unapproved modifications.
- (c) You are responsible for presenting your small off-road engine to a Maruyama Manufacturing Company, Inc. distribution center as soon as a problem exists. The warranty repairs should be completed in a reasonable amount of time, not to exceed 30 days.

If you have any questions regarding your warranty rights and responsibilities, you should contact Maruyama U.S., Inc. at **1-866-783-7400**.

Emission System Parts

Exhaust Emission
Carburetor
Muffler
Catalytic Converter
Ignition Coil / Magneto
Spark Plug
Air Filter
EGR Valve (piston)
Fuel Filter

Evaporative Emission
Fuel Tank

Contents

	Page US-		Page US-
Limited Warranty Statement	1	Mixing Gasoline And Oil	17
Federal Emission Control	3	Starting And Stopping	18
California Emission Control	5	Operation.....	19
Introduction	7	[Loop Handle Models]	
Safety	8	Trimmer Operating Position	20
Operator Safety	8	Cutting with Trimmer Head.....	20
Trimmer/Brushcutter Safety	8	[Handlebar Handle Models]	
Fuel Safety	9	Brushcutter Operating Position.....	22
Trimmer/Brushcutter Operating Safety	9	Cutting Direction	23
Safety and Instruction Decals	11	Cutting Blades.....	23
Product Description.....	11	Maintenance.....	23
Assembly.....	12	Idle Speed Adjustment.....	23
Loop Handle Installation.....	12	Air Filter.....	24
Handlebar Installation	12	Fuel Filter.....	25
[Loop Handle Models]		Spark Plug.....	26
Installing Debris Shield.....	12	Cylinder Cooling Fins.....	26
[Handlebar Handle Models]		Spark Arrester	27
Installing Debris Shield	13	Exhaust Muffler	28
[Handlebar Handle kit Models]		Gearcase.....	28
Installing Debris Shield	14	General Cleaning and Tightening	29
Installing Trimmer Head.....	14	Blade Sharpening.....	29
Installing Brushcutter Blade	15	Storage.....	30
Attaching Strap	15	Troubleshooting	31
Before Operation.....	16	Maintenance Period.....	31
Oil and Fuel.....	16	Specifications	32

Introduction

Thank you for purchasing a Maruyama product.

Maruyama, its distributors, and dealers want you to be completely satisfied with your new product. Please feel free to contact your local Authorized Service Dealer for help with service, genuine Maruyama parts, or other information you may require.

Whenever you contact your Authorized Service Dealer or the factory, always know the serial number of your product. This number will help the Service Dealer or Service Representative provide exact information about your specific product. You will find the model and serial number located in a unique place on the product (Product Description on page US-11).

For your convenience, write the product model name and serial number in the space to the right.

Model Name _____
Serial No. _____

Read this manual carefully to learn how to operate and maintain your product correctly. Reading this manual will help you and others avoid personal injury and damage to the product.

Although Maruyama designs, produces and markets safe, state-of-the-art products, you are responsible for using the product properly and safely. You are also responsible for training persons who you allow to use the product about safe operation.

The Maruyama warning system in this manual identifies potential hazards and has special safety messages that help you and others avoid personal injury, even death. DANGER, WARNING and CAUTION are signal words used to identify the level of hazard. However, regardless of the hazard, be extremely careful.

DANGER signals an extreme hazard that will cause serious injury or death if the recommended precautions are not followed.

WARNING signals a hazard that may cause serious injury or death if the recommended precautions are not followed.

CAUTION signals a hazard that may cause minor or moderate injury if the recommended precautions are not followed. Two other words are also used to highlight information. "Important" calls attention to special mechanical information and "Note" emphasizes general information worthy of special attention.

Safety

Operator Safety

1. Read and understand this Operator's Manual before using this product. Be thoroughly familiar with the proper use of this product.
2. Never allow children to operate the Trimmer/Brushcutter. It is not a toy. Never allow adults to operate the unit without first reading the Operator's Manual.
3. Always wear eye protection that complies with ANSI (American National Standards Institute) Z87-1.



4. Always wear hearing protection.



5. Always wear heavy, long pants, a long sleeved shirt, boots and gloves. Do not wear loose clothing, jewelry, short pants, sandals, or go barefoot. Secure hair so it is above shoulder length.
6. Never operate this Trimmer/Brushcutter when you are tired, ill, or under the influence of alcohol, drugs or medication.
7. Never start or run the engine inside a closed room or building. Breathing exhaust fumes can cause death.



8. Keep handles clean of oil, fuel and dirt.

Trimmer/Brushcutter Safety

1. Make sure the Trimmer/Brushcutter is assembled correctly and that the Cutting Attachment is correctly installed and securely fastened as instructed in the Assembly section.
2. Inspect the Trimmer/Brushcutter before each use. Replace damaged parts. Check for fuel leaks. Make sure all fasteners are in place and tightened securely. Follow the maintenance instructions beginning on page US-23.
3. Make sure the cutting head does not rotate at engine idle speed. Refer to Idle Speed Adjustment, page US-23.
4. Inspect the cutting head and replace any parts that are cracked, chipped or damaged before using the Trimmer/Brushcutter.

5. Make sure the debris shield is installed and positioned correctly before using the Trimmer/Brushcutter.
6. Never use a cutting head or replacement parts that are not approved by Maruyama.
7. Maintain the Trimmer/Brushcutter according to the recommended maintenance intervals and procedures in the Maintenance section on page US-23.
8. Shut off the engine and be certain the cutting head has completely stopped rotating before inverting the Trimmer/Brushcutter, performing maintenance on or working on the machine.
9. If running problems or excessive vibration occur, stop immediately and inspect the unit for the cause. If the cause cannot be determined or is beyond your ability to correct, return the Trimmer/Brushcutter to your servicing dealer for repair.

Fuel Safety

1. Gasoline is highly flammable and must be handled and stored carefully. Use a container approved for fuel to store gasoline and/or fuel/oil mixture.
2. Mix and pour fuel outdoors, where there are no sparks or flames.
3. Do not smoke near fuel or Trimmer/Brushcutter, or while using the Trimmer/Brushcutter.
4. Do not overfill the fuel tank. Stop filling 1/4-1/2 inch (6 mm-13 mm) from the top of the tank.
5. Wipe up any spilled fuel before starting the engine.

6. Move the Trimmer/Brushcutter at least 10 feet (3 m) away from the fueling location before starting the engine.

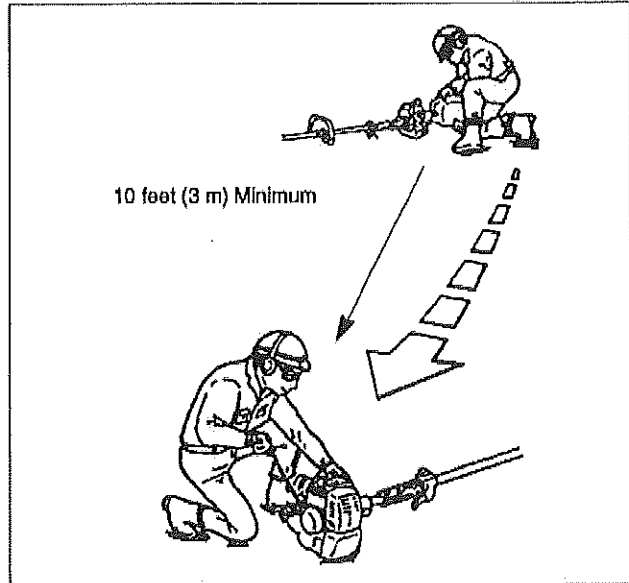

7. Do not remove the fuel tank cap while the engine is running, or right after stopping the engine.
8. Allow the engine to cool before refueling.
9. Drain the tank and run the engine dry before storing the unit.
10. Store fuel and Trimmer/Brushcutter away from open flame, sparks and excessive heat. Make sure fuel vapors cannot reach sparks or open flames from water heaters, furnaces, electric motors, etc.

Trimmer/Brushcutter Operating Safety

1. **THIS TRIMMER BRUSHCUTTER CAN CAUSE SERIOUS INJURIES.** Read the instructions carefully. Be familiar with all controls and the proper use of the Trimmer/Brushcutter.
2. Make sure the 3 mm hex wrench has been removed from the gearcase and boss adapter before you start the engine.

3. Avoid using the Brushcutter near rocks, gravel, stones and similar material which can become dangerous projectiles.
4. Inspect your work area before you begin. Remove objects such as broken glass, nails, wire and rocks which can become dangerous projectiles if thrown by the Trimmer/Brushcutter. Remove string, rope or similar materials which can become entangled in the cutting head.
5. Keep children, bystanders and animals outside a 50 ft. (15 m) radius from the operator and Trimmer/Brushcutter.

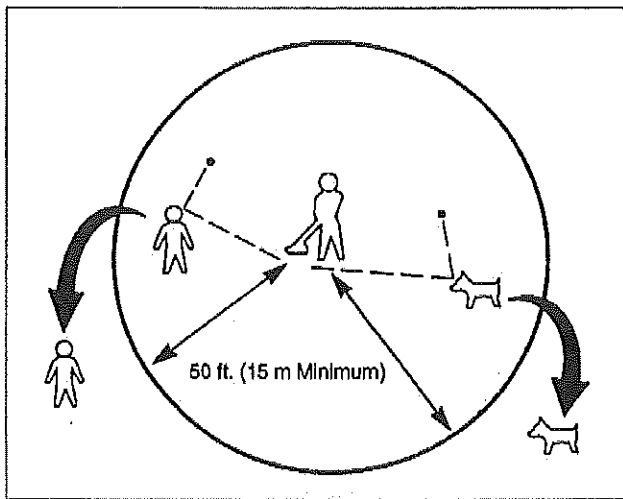

6. If you are approached while operating the Trimmer/Brushcutter, stop the engine and cutting head rotation.
7. Never allow children to operate the Trimmer/Brushcutter.
8. Use the Trimmer/Brushcutter only in daylight or good artificial light.
9. Never operate the Trimmer/Brushcutter without proper guards or other protective safety devices in place.
10. Always keep the Trimmer/Brushcutter on the right side of your body.
11. Do not raise the cutting head above waist level.

12. Do not put hands or feet near or under any rotating parts. Keep clear at all times. Keep all parts of your body away from the rotating cutting attachment and hot surfaces such as the muffler.
13. When cutting heavy brush or small trees, always move the Brushcutter from right to left to prevent kick-back.

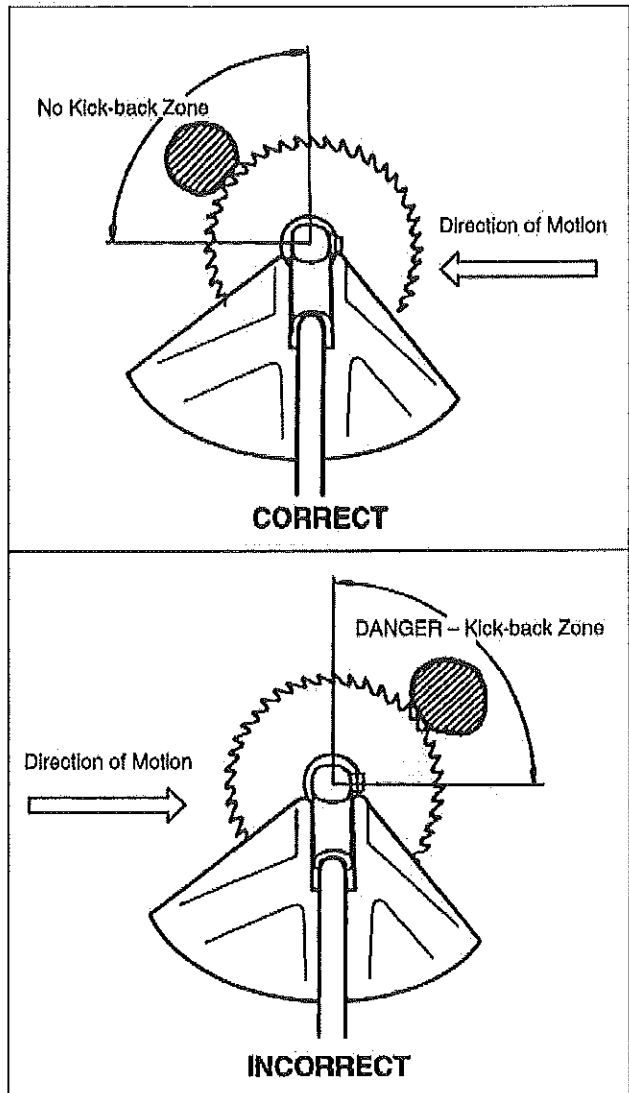

14. Keep firm footing and balance. Do not overreach.
15. Use the right tool for the job. Do not use the Trimmer/Brushcutter for any job that is not recommended by Maruyama.

Safety and Instruction Decals



Safety decals and instructions are easily visible to the operator and are located near any area of potential danger. Replace any decal that is damaged or lost.



ON SHAFT
(Part No.221501)



ON SHAFT
(Part No.221502)

Product Description

B23L/BC2621/B30L/B30L TURBO

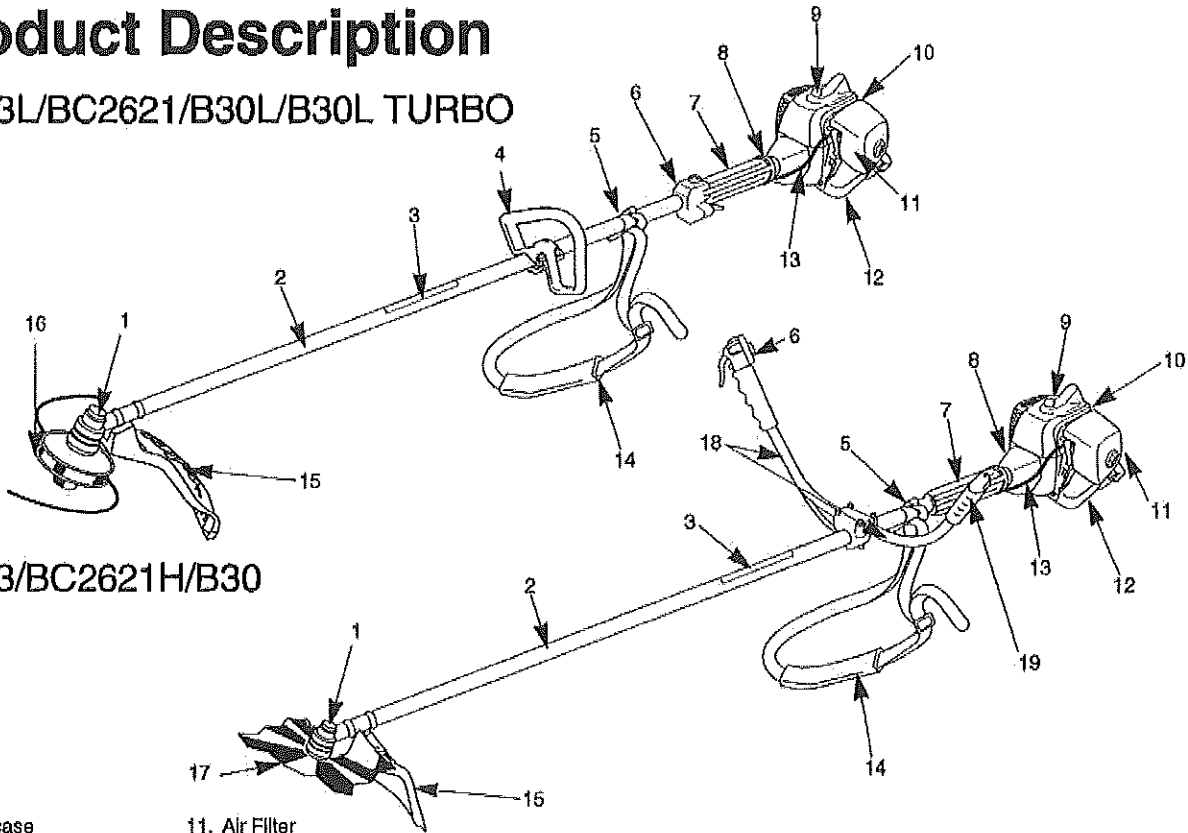

B23/BC2621H/B30

- 1. Gearcase
- 2. Shaft Assembly
- 3. Model Name
- 4. Loop handle
- 5. Attachment Ring for Shoulder Strap
- 6. Throttle Trigger and Stop Switch
- 7. Shaft Grip
- 8. Clutch Drum Housing
- 9. Engine
- 10. Serial Number (on rear of engine)

- 11. Air Filter
- 12. Fuel Tank
- 13. Throttle Cable and Stop Switch Wires
- 14. Shoulder Strap
- 15. Debris Shield
- 16. Trimmer head
- 17. Brushcutter Blade
- 18. Handlebar
- 19. Handle Grip

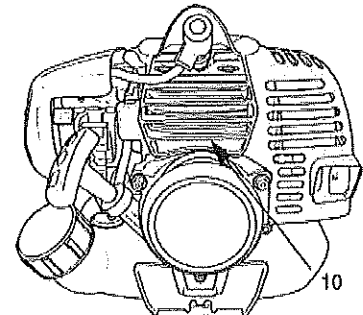

Assembly

Loop Handle Installation

The loop handle kit contains a package of four screws, nuts and the bottom clamp for the loop handle.

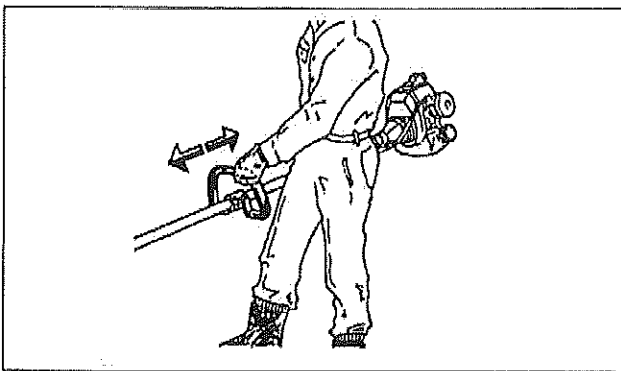
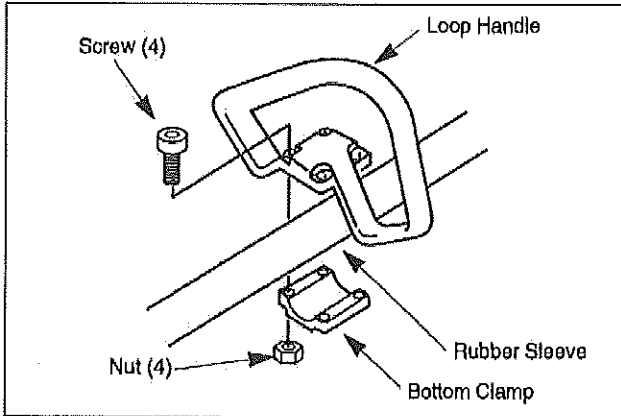

1. Place the loop handle and the bottom clamp approximately 9 inches (22.8 cm) from the end of the stop switch/throttle trigger assembly for an initial handle position.
2. Install the four screws and nuts. Leave the screws finger-tight.
3. Reposition the loop handle up or down the drive shaft to the most comfortable position, but no closer than 9 inches (22.8 cm) from the end of the stop switch.
4. Tighten the screws and nuts.

Handlebar Installation

IMPORTANT: Be careful not to damage the throttle cable and stop switch wires when you remove the handlebars from the shipping carton.

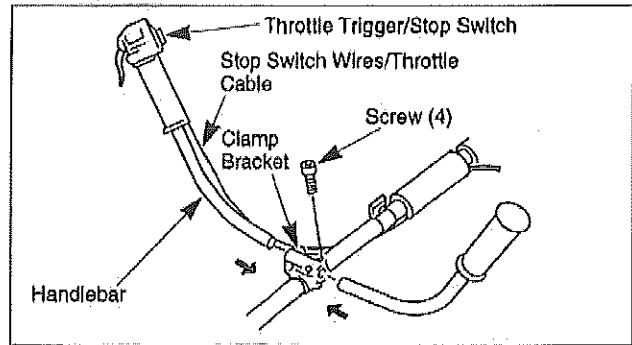

1. Loosen the four screws on the top of the clamp bracket.
2. Insert the left and right handlebars into the clamp bracket. Note that the handlebar with the throttle trigger and stop switch goes on the right-hand side of the Brushcutter.
3. Adjust the handlebar to the desired position, then tighten the four screws.

[Loop Handle Models] Installing Debris Shield

⚠ WARNING

POTENTIAL HAZARD

- Foreign objects can be thrown by the Trimmer.

WHAT CAN HAPPEN

- Contact with thrown objects can cause personal injury.

HOW TO AVOID THE HAZARD

- Never operate the Trimmer without the debris shield in place.

⚠ CAUTION

POTENTIAL HAZARD

- The cutoff blade is sharp.

WHAT CAN HAPPEN

- Contact with cutoff blade could cause serious cuts or personal injury.

HOW TO AVOID THE HAZARD

- Keep hands, feet and clothing away from cutoff blade.

1. Fasten the string cutoff blade to the debris shield with two M5 x 12 screws and hex nuts as shown.

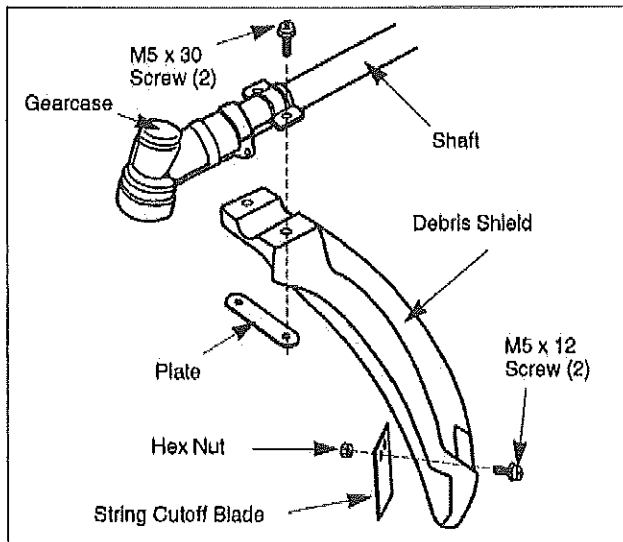

2. Attach the debris shield to the shaft with the two M5 x 30 screws and plate as shown.

[Handlebar Handle Models] Installing Debris Shield

⚠ WARNING

POTENTIAL HAZARD

- Foreign objects can be thrown by the Trimmer/Brushcutter.

WHAT CAN HAPPEN

- Contact with thrown objects can cause personal injury.

HOW TO AVOID THE HAZARD

- Never operate the Trimmer/Brushcutter without the debris shield in place.

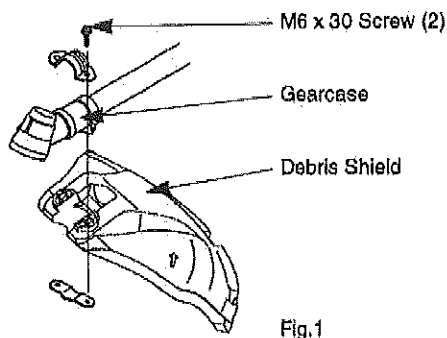

Fig.1

Debris Shield

Attach the debris shield to the gearcase with the two M6 x 30 screws as shown on Fig. 1.

Extension Shield

(Install the string cutoff blade and shield extension to the debris shield.)

1. Insert the square nut into shield extension as shown on Fig. 2.

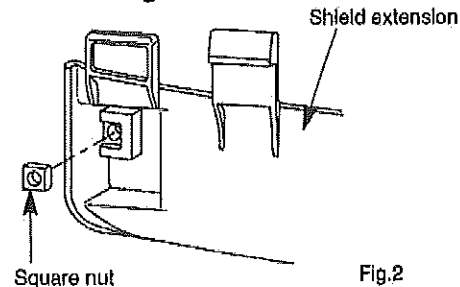

Fig.2

2. Attach the String Cutoff Blade to shield extension using M5 x 20 Screw, locking with square nut (on Fig.2) as shown on Fig. 3.

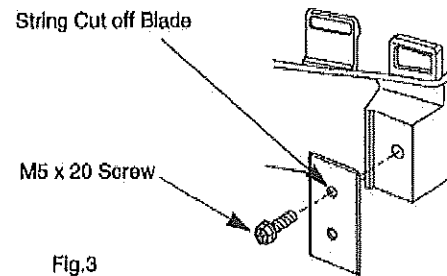

Fig.3

3. Enter the guide in the slot of debris shield on Fig. 4.
4. Make sure place the three hooks into the position on the shield as shown on Fig.5.

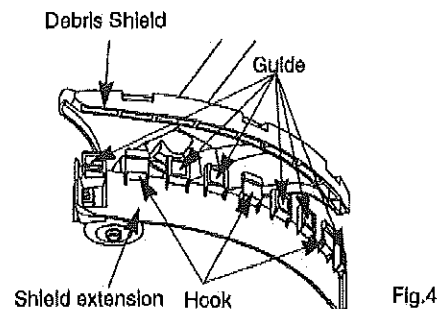

Fig.4

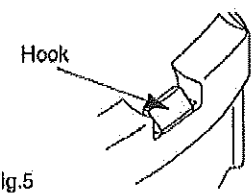

Fig.5

[Handlebar Handle Kit Models] Installing Debris Shield

⚠ WARNING

POTENTIAL HAZARD

- Foreign objects can be thrown by Brushcutter.

WHAT CAN HAPPEN

- Contact with thrown objects can cause personal injury.

HOW TO AVOID THE HAZARD

- Never operate the Brushcutter without the debris shield in place.

1. Exchange the M5 x 12 screw for with use the debris shield as shown.
2. Attach the debris shield to the shaft with the two M5 x 30 screws and plate as shown.

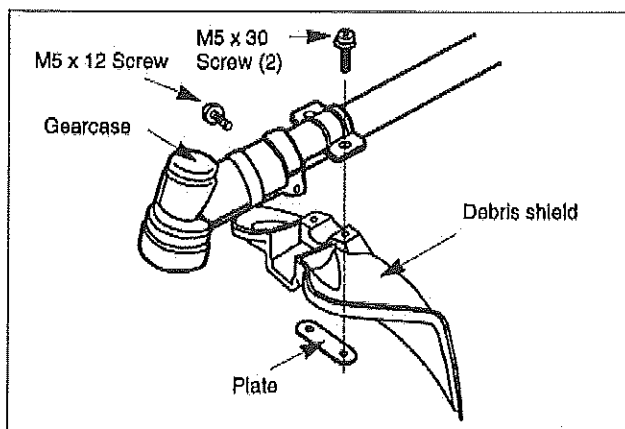

Installing Trimmer Head

IMPORTANT: The boss adapter must be installed on the attaching shaft between the gearcase and the trimmer head as shown. And Trimmer head adapter is left-hand thread.

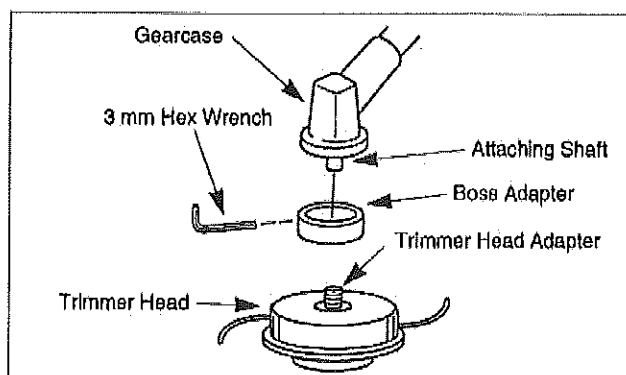

1. Install the boss adapter onto the attaching shaft out of the gearcase.
2. Align the hole in the boss adapter with the hole in the gearcase.
3. Insert the 3 mm hex wrench into the holes in the boss adapter and gearcase to lock the attaching shaft.
4. Thread the trimmer head adapter into the attaching shaft, then tighten the trimmer head firmly by hand.

⚠ CAUTION

POTENTIAL HAZARD

- If the trimmer head is not adequately tightened, it can come loose from the Trimmer during use.

WHAT CAN HAPPEN

- This may cause damage to property or personal injury.

HOW TO AVOID THE HAZARD

- Make sure the trimmer head is securely fastened to the attaching shaft in the gearcase.

Installing Brushcutter Blade

⚠ CAUTION

POTENTIAL HAZARD

- If the Brushcutter blade is not adequately tightened, it can come loose from the Brushcutter during use.

WHAT CAN HAPPEN

- This may cause damage to property or personal injury.

HOW TO AVOID THE HAZARD

- Make sure the Brushcutter blade is securely fastened to the splined shaft in the gearcase.

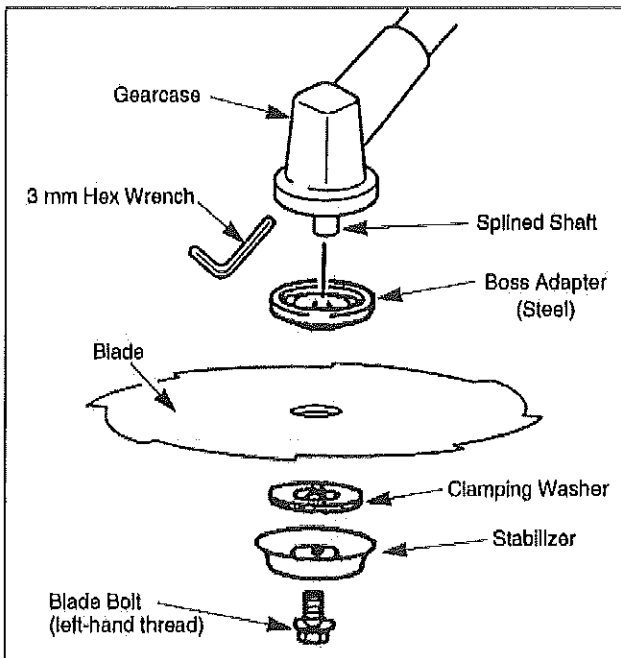

1. Remove the blade bolt, stabilizer and clamping washer from the splined shaft out of the gearcase.

Note: The blade bolt has left-hand threads.

⚠ WARNING

POTENTIAL HAZARD

- Brushcutter blade is sharp.

WHAT CAN HAPPEN

- Contact with sharp blade can cause serious personal injury.

HOW TO AVOID THE HAZARD

- Wear gloves when you handle the blade.

2. Install the brushcutter blade onto the boss adapter, then reinstall the clamping washer, stabilizer and blade bolt.

Note: In case of brushcutter blade, please replace boss adapter from aluminum to steel. The steel boss adapter is contained in the blade guard kit.

3. Align the hole in the boss adapter with the hole in the gearcase.
4. Insert a 3 mm hex wrench or other suitable tool into the holes in the boss adapter and gearcase to lock the splined shaft.
5. Tighten the blade bolt to 100 in.-lbs. (11.3 N•M).
6. Remove the 3 mm hex wrench from the boss adapter and gearcase.

Attaching Strap

⚠ WARNING

POTENTIAL HAZARD

- Without the strap installed on the Brushcutter, the blade can produce side thrust which can expose the operator and bystanders to blade contact.

WHAT CAN HAPPEN

- Contact with the Brushcutter blade can cause severer personal injury.

HOW TO AVOID THE HAZARD

- Never operate the Brushcutter without installing and using the strap.

Snap the strap hook into the ring on the drive shaft. To detach the strap quickly from the Brushcutter, pull upward on the red band.

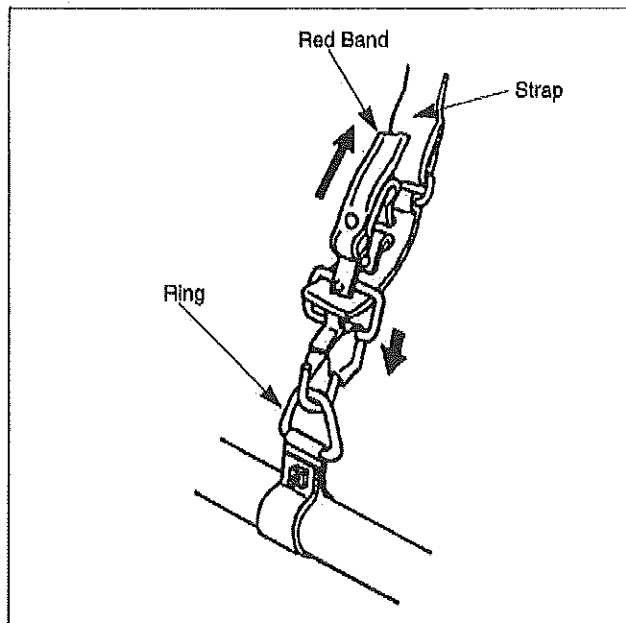

Before Operation

Oil and Fuel

⚠ DANGER

POTENTIAL HAZARD

- In certain conditions gasoline is extremely flammable and highly explosive.

WHAT CAN HAPPEN

- A fire or explosion from gasoline can burn you, others, and cause property damage.

HOW TO AVOID THE HAZARD

- Use a funnel and fill the fuel tank outdoors, in an open area, when the engine is cold. Wipe up any gasoline that spills.
- Do not fill the fuel tank completely full. Add gasoline to the fuel tank until the level is 1/4" to 1/2" (6 mm to 13 mm) below the bottom of the filler neck. This empty space in the tank allows gasoline

to expand.

- Never smoke when handling gasoline, and stay away from an open flame or where gasoline fumes may be ignited by a spark.
- Store gasoline in an approved container and keep it out of the reach of children.
- Never buy more than a 30-day supply of gasoline.

1. Do not smoke near fuel.
2. Mix and pour fuel outdoors and where there are no sparks or flames.
3. Always shut off the engine before refueling. Never remove the fuel tank cap while the engine is running or just right after stopping the engine.

⚠ WARNING

POTENTIAL HAZARD

- Gasoline contains gasses that can build up pressure inside a gas tank.

WHAT CAN HAPPEN

- Fuel can be sprayed on you when removing gas cap.

HOW TO AVOID THE HAZARD

- Remove fuel cap slowly to avoid injury from fuel spray.
4. Always open the fuel tank cap slowly to release any possible overpressure inside the tank.
 5. Do not overfill the fuel tank. Stop filling 1/4-1/2 inch (6 mm-13 mm) from the top of the tank.
 6. Tighten the fuel tank cap carefully but firmly after refilling.
 7. Wipe up any spilled fuel before starting the engine.

8. Move the Trimmer/Brushcutter at least 10 feet (3 m) away from the fueling location and fuel storage container before starting the engine.

Recommended Oil Type

Only use a two-cycle engine oil formulated for use in high-performance, air-cooled two-cycle engines. Maruyama brand 2-cycle oil is formulated for use in high-performance, air-cooled two-cycle engines.

IMPORTANT: Do not use National Marine Manufacturer's Association (NMMA) or BIA certified oils. This type of 2-cycle engine oil does not have the proper additives for air-cooled, 2-cycle engines and can cause engine damage.

Do not use automotive motor oil. This type of oil does not have the proper additives for air-cooled, 2-cycle engines and can cause engine damage.

Recommended Fuel Type

Use clean, fresh lead-free gasoline, including *oxygenated* or *reformulated* gasoline, with an octane rating of 89 or higher. To ensure freshness, purchase only the quantity of gasoline that can be used in 30 days. Use of lead-free gasoline results in fewer combustion chamber deposits and longer spark plug life. Use of premium grade fuel is not necessary or recommended.

Use of Fuel Additives

IMPORTANT: NEVER USE ALCOHOL, GASOHOL CONTAINING MORE THAN 10% ALCOHOL BECAUSE ENGINE FUEL SYSTEM DAMAGE COULD RESULT.

DO NOT USE FUEL ADDITIVES OTHER THAN THOSE MANUFACTURED FOR FUEL STABILIZATION DURING STORAGE SUCH AS MARUYAMA'S STABILIZER/CONDITIONER OR A SIMILAR PRODUCT. MARUYAMA'S STABILIZER/CONDITIONER IS A PETROLEUM DISTILLATE BASED CONDITIONER/STABILIZER.

MARUYAMA DOES NOT RECOMMEND STABILIZERS WITH AN ALCOHOL BASE SUCH AS ETHANOL, METHANOL OR ISOPROPYL. ADDITIVES SHOULD NOT BE USED TO TRY TO ENHANCE THE POWER OR PERFORMANCE OF MACHINE.

Mixing Gasoline And Oil

IMPORTANT: The engine used on this Trimmer/Brushcutter is of a 2-cycle design. The internal moving parts of the engine, i.e., crankshaft bearings, piston pin bearings and piston to cylinder wall contact surfaces, require oil mixed with the gasoline for lubrication.

Failure to add oil to the gasoline or failure to mix oil with the gasoline at the appropriate ratio will cause major engine damage which will void your warranty.

For your fuel premix, use Maruyama Premium 2-cycle Oil Mix, or equivalent ISO-L-EGD & JASO FD oil with a minimum 89 octane high quality gasoline. Maruyama 2-cycle oil is specially formulated to meet the requirements of high-performance, low-emission air-cooled 2-cycle engines. Use of other oils may lead to service issues which may not be covered by your warranty.

Fuel Mixture

The fuel: oil ratio is 50 parts gasoline to 1 part oil or 50:1.

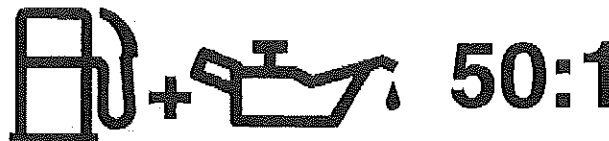

Note: Never use a mixing ratio less than 50:1 regardless of the oil package mixing instructions. Ratios less than 50:1, (for example, 60:1, 80:1, 100:1), reduce the amount of lubrication to the internal moving parts of the engine and can cause damage.

Fuel Mixture Chart

Gasoline	50:1 2-cycle oil
1 gallon	2.6 oz.
2 gallons	5.1 oz.
5 gallons	12.8 oz.
1 litre	20 ml
5 litre	100 ml

Mixing Instructions

IMPORTANT: Never mix gasoline and oil directly in the Trimmer/Brushcutter fuel tank.

1. Always mix fuel and oil in a clean container approved for gasoline.
2. Mark the container to identify it as fuel mix for the Trimmer/Brushcutter.
3. Use regular unleaded gasoline and fill the container with half the required amount of gasoline.
4. Pour the correct amount of oil into the container then add the remaining amount of gasoline.
5. Close the container tightly and shake it momentarily to evenly mix the oil and the gasoline before filling the fuel tank on the Trimmer/Brushcutter.
6. When refilling the Trimmer/Brushcutter fuel tank, clean around the fuel tank cap to prevent dirt and debris from entering the tank during cap removal.
7. Always shake the premix fuel container momentarily before filling the fuel tank.
8. Always use a spout or funnel when fueling to reduce fuel spillage.

9. Fill the tank only to within 1/4-1/2 inch (6 mm-13 mm) from the top of the tank. Avoid filling to the top of the tank filler neck.

Starting And Stopping

Before Starting The Engine

1. Fill the fuel tank as instructed in the Operation section of this manual (US-16).
2. Rest the Trimmer/Brushcutter on the ground.
3. Make sure the cutting attachment is clear of any broken glass, nails, wire, rocks or other debris.
4. Keep all bystanders, children and animals away from the working area.

Cold Starting Procedure

This Trimmer is equipped with a fuel primer and a choke system. To start a "cold" engine properly, perform the following procedure:

1. Pump the primer bulb at the bottom of the carburetor until fuel can be seen flowing through the fuel return line to the fuel tank. (Flowing fuel should be almost clear, not foamy or full of bubbles.)

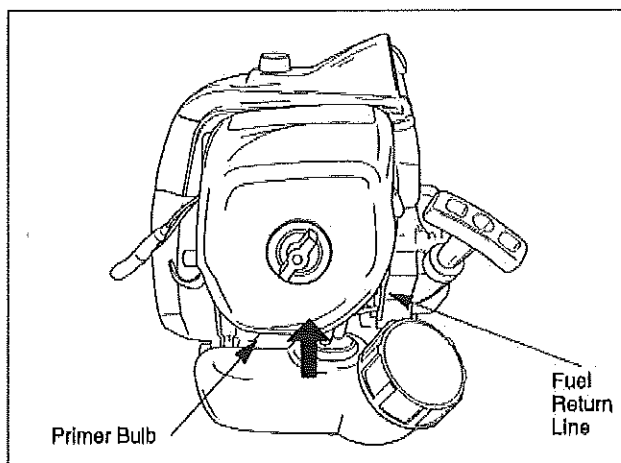

2. Move the choke lever to the closed (☐) position and move the stop switch to the "ON" position.

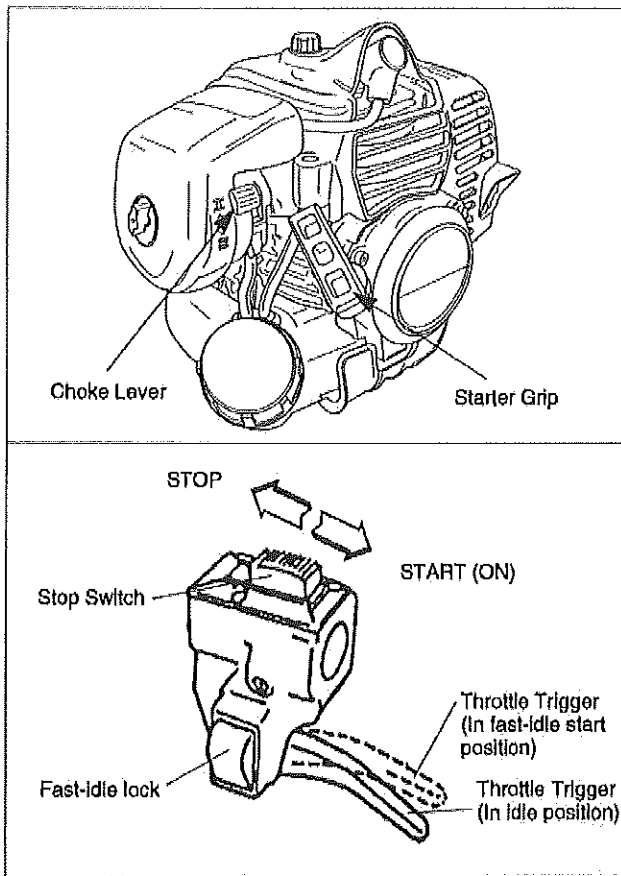

4. After the engine starts, squeeze and release the throttle trigger to return it to the idle position, then move the choke lever to the open (☐) position.

If the engine stops running before you move the choke lever to the open (☐) position:

- A. Go ahead and open the choke.
- B. Make sure the throttle trigger is set to the idle position.
- C. Pull the starter grip until the engine starts.

Hot Restart

To start an engine that is already warmed up (hot restart), or if the ambient temperature exceeds 68°F (20°C):

1. Pump the primer bulb at the bottom of the carburetor until fuel can be seen flowing through the fuel return line to the fuel tank.
2. Move the choke lever to the open (☐) position and move the stop switch to the "ON" position.
3. Leave the throttle trigger in the idle position and pull the starter grip.
4. If the engine fails to start after three to four pulls, follow the instruction in the Cold Starting Procedure section (US-18).

If the engine fails to start after you follow the above procedures, contact an authorized Maruyama dealer.

To Stop The Engine:

1. Release the throttle trigger.
2. Slide the stop switch to the "STOP" position.

Operation

CAUTION

- Read the Safety instructions on US-8 concerning proper use of the String Trimmer.

WARNING

POTENTIAL HAZARD

- The components of your recoilstarter assembly are under high spring tension. If improperly disassembled these parts may strike you with considerable force, possibly causing personal injury.

WHAT CAN HAPPEN

- Contact with the parts can cause severe personal injury.

HOW TO AVOID THE HAZARD

- Never attempt to disassemble your recoil starter assembly yourself. Always consult your authorized Maruyama dealer for repair by qualified service technicians.

3. Lock the throttle trigger in the fast-idle start position, then pull the starter grip.

[Loop Handle Models] Trimmer Operating Position

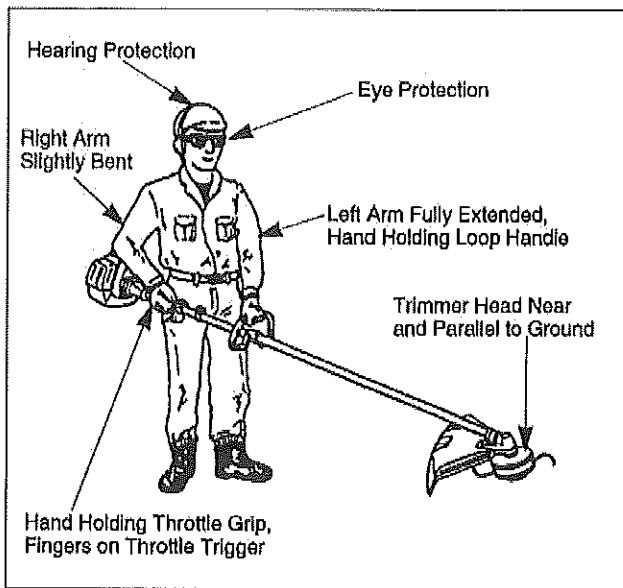

Before using the Trimmer, check the following:

1. Make sure the 3mm hex wrench has been removed from the gearcase and boss adapter before you start the engine.
2. The Trimmer should be on the operator's right side.
3. The operator's right hand should be holding the shaft grip, with his or her fingers on the throttle trigger. The right arm should be slightly bent.
4. The left hand should be holding the loop handle with the fingers and thumb fully enclosed around the grip. The left arm should be extended. Reposition the loop handle up or down the drive-shaft if necessary for a comfortable position.
5. The Trimmer weight should be evenly distributed between the arms. The trimmer head should be near and parallel to the ground.
6. Accelerate and hold the engine at cutting speed before entering the material to be cut.
7. Always release the throttle trigger and allow the engine to return to idle speed when not cutting.
8. Stop the Trimmer engine when moving between work sites.

⚠ CAUTION

- Always wear gloves and protective clothing when operating the String Trimmer.
- If the trimmer head becomes jammed, stop the engine immediately.
- Make certain all moving parts have stopped and disconnect the spark plug before inspecting the equipment for damage.
- Never use a String Trimmer that has chipped, cracked or broken trimmer head.

Cutting with Trimmer Head

- The tip of the line does the cutting. The line should stay extended while cutting.

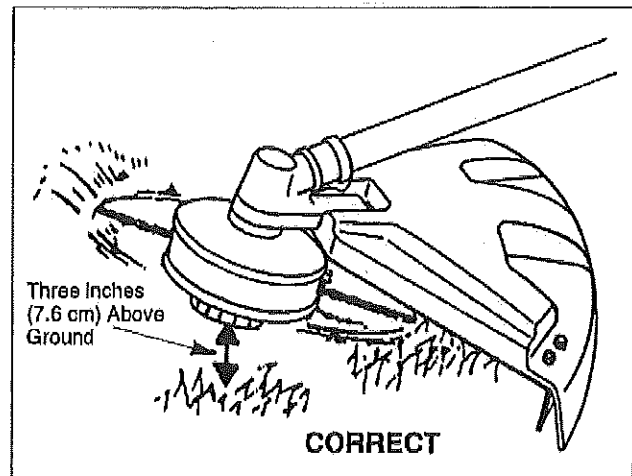

- Do not force the line into the material. Forcing the line will cause it to slap against the material, increasing line usage and causing poor cutting results.

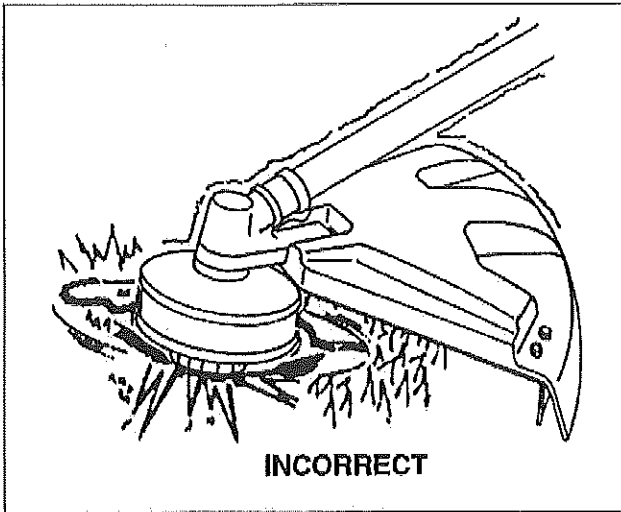

Trimming

Hold the bottom of the trimmer head about 3 in. (7.6 cm) above the ground and at an angle. Allow only the tip of the line to make contact.

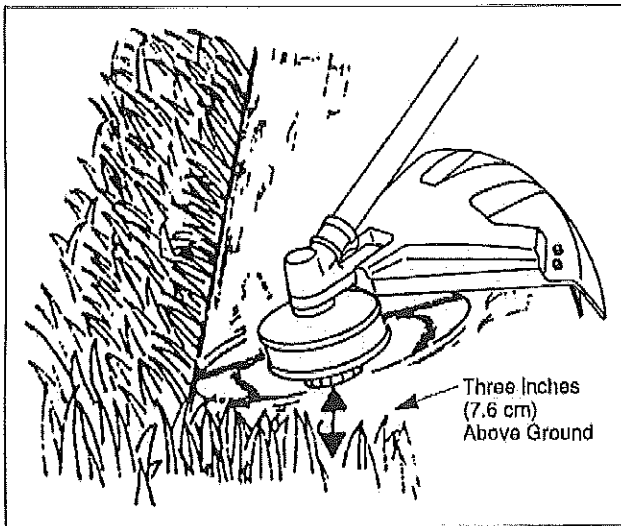

Scaling

To remove unwanted vegetation, hold the trimmer head about 3 in. (7.6 cm) above the ground and at an angle. Allow the tip of the line to strike the ground cutting the vegetation off at the surface.

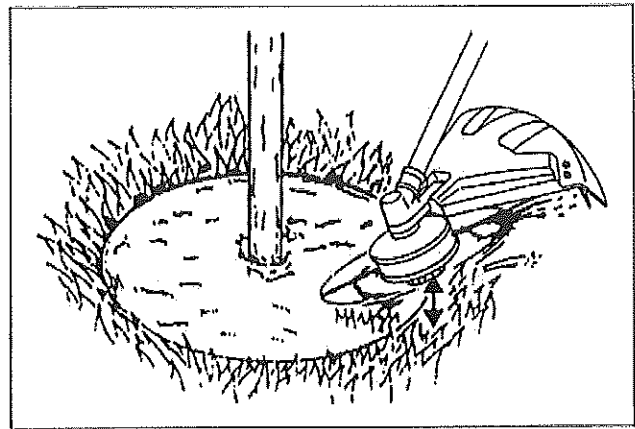

Mowing

Keep the line parallel to the ground and use a gentle side-to-side motion.

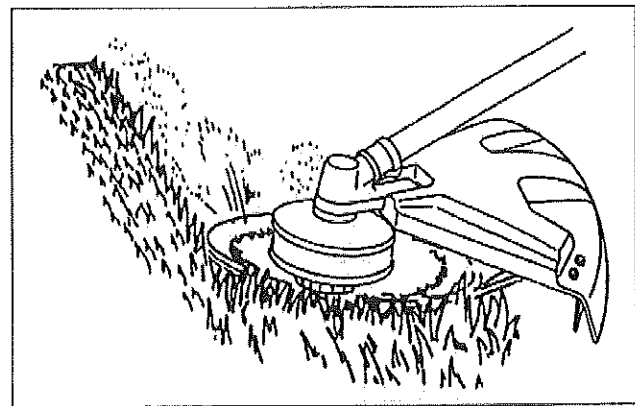

[Handlebar Handle Models]

⚠ WARNING

POTENTIAL HAZARD

- Foreign objects can be thrown by Brushcutter.

WHAT CAN HAPPEN

- Contact with thrown objects can cause personal injury.

HOW TO AVOID THE HAZARD

- Never operate the Brushcutter without the debris shield in place.

⚠ CAUTION

- Read the Safety instructions on page US-8 concerning proper use of the Brushcutter.

Brushcutter Operating Position

Before using the Brushcutter, check the following:

1. Make sure the 3 mm hex wrench has been removed from the gearcase and boss adapter before you start the engine.

⚠ WARNING

POTENTIAL HAZARD

- Without the strap installed, the Brushcutter blade can produce side thrust which can expose the operator and bystanders to blade contact.
- If the Brushcutter is not correctly positioned on the operator's right side, the blade can produce side thrust which can expose the operator and bystanders to blade contact.

WHAT CAN HAPPEN

- Contact with the Brushcutter blade can cause severe personal injury.

HOW TO AVOID THE HAZARD

- Never operate the Brushcutter without installing and using the strap.
- Always operate the Brushcutter with the unit on your right side.

2. The operator must be wearing the strap attached to the Brushcutter, and the Brushcutter must be on the operator's right side.
3. The operator's right hand should be holding the right-hand throttle grip, with his or her fingers on the throttle trigger.
4. The left hand should be holding the left-hand grip with the fingers and thumb fully enclosed around the grip.
5. Accelerate and hold the engine at cutting speed before entering the material to be cut.
6. Always release the throttle trigger and allow the engine to return to idle speed when not cutting.

7. Stop the Brushcutter engine when moving between work sites.

⚠ CAUTION

- Always wear gloves and protective clothing when operating the Brushcutter.
- If the Brushcutter blade becomes jammed, stop the engine immediately.
- Make certain all moving parts have stopped and disconnect the spark plug before inspecting the equipment for damage.
- Never use a Brushcutter that has chipped, cracked or broken cutting attachment or shield.

IMPORTANT: To detach the strap quickly from the Brushcutter, pull upward on the red band.

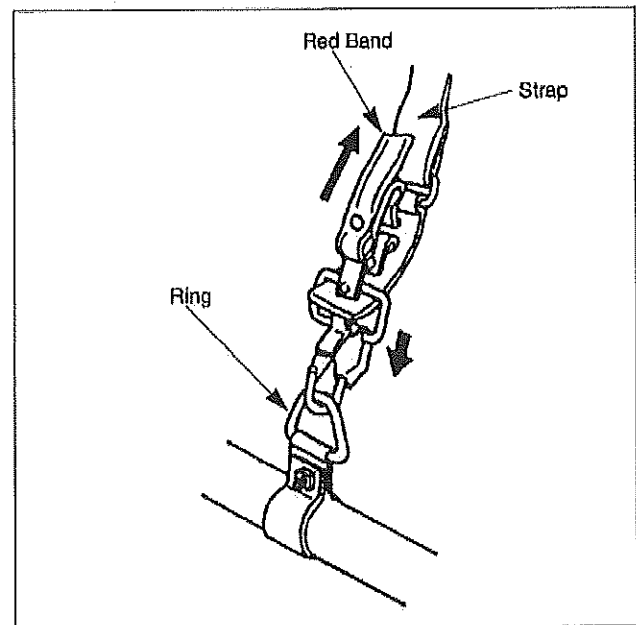

Cutting Direction

⚠ WARNING

POTENTIAL HAZARD

- Cutting heavy brush or small trees from the wrong direction can cause the Brushcutter blade to kick back.

WHAT CAN HAPPEN

- Contact move the Brushcutter blade can cause severe personal injury.

HOW TO AVOID THE HAZARD

- Always move the Brushcutter from right to left when cutting heavy brush or small trees as shown.

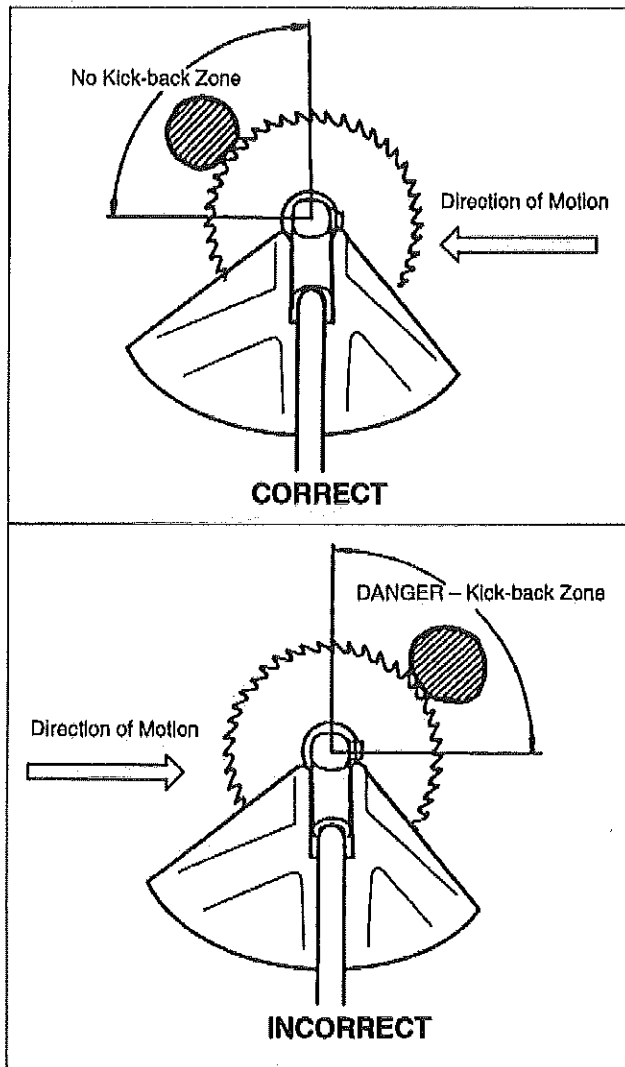

When cutting heavy brush or small trees, always move the Brushcutter from right to left. Moving the Brushcutter from left to right can cause the blade to kick back.

Cutting Blades

1. Use only the correct blade (Maruyama genuine part) approved for the application and model Brushcutter.
2. Carefully check the condition of the blades before and after operation.
3. Sharpen dull blades. Replace any blade that is worn, cracked or damaged.
4. If a blade produces eccentric rotation or vibration, replace the blade and the boss adapter with genuine Maruyama parts.

Maintenance

Maintenance, replacement or repair of emission control devices and systems may be performed by any repair establishment or individual; however, warranty repairs must be performed by a dealer or service center authorized by Maruyama Manufacturing Company, Inc. The use of parts that are not equivalent in performance and durability to authorized parts may impair the effectiveness of the emission control system and may have a bearing on the outcome of a warranty claim.

Maintenance on today's low-emission engines is even more critical for longest life and best performance. particularly critical are air and fuel filters, spark plug heat range, cooling air intake area and proper gaps of coil and plug.

Idle Speed Adjustment

This Trimmer/Brushcutter is equipped with non-adjustable fuel mixture carburetor. The engine idle speed is the only adjustment for the operator.

⚠ WARNING

- Idle speed adjustment should be checked each time the unit is operated.

⚠ WARNING

POTENTIAL HAZARD

- Engine must be running to make carburetor adjustments.
- When engine is running, cutting head is rotating and other parts are moving.

WHAT CAN HAPPEN

- Contact with rotating cutting head or other moving parts could cause serious personal injury or death.

HOW TO AVOID THE HAZARD

- Keep hands, feet and clothing away from cutting head and other moving parts.
- Keep all bystanders and pets away from unit while making carburetor adjustments.

The cutting head may be rotating during idle speed adjustment. Wear the recommended personal protective equipment and observe all safety instructions. Keep hands and body away from the cutting head.

When the throttle trigger is released, the engine should return to an idle speed between 2700 and 3300 RPM, or just below the clutch engagement speed. The cutting head must not rotate and the engine should not stall (stop running) at engine idle speed.

To adjust the engine idle speed, rotate the idle speed adjustment screw on the carburetor.

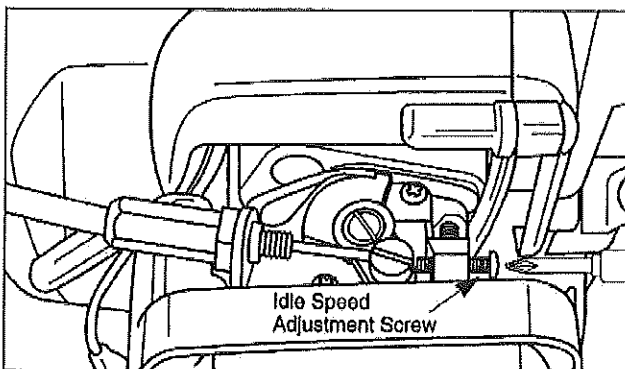

- Turn the idle speed screw in (clockwise) to increase the engine idle speed.
- Turn the screw out (counterclockwise) to decrease the engine idle speed.

If idle speed adjustment is necessary, and after adjustment the cutting head rotates or the engine stalls, stop using the Trimmer/ Brushcutter immediately!

Contact your local authorized Maruyama Dealer for assistance and servicing.

Air Filter

Maintenance Interval

- The air filter should be cleaned **daily**, or more often when working in extremely dusty conditions.
- Replace after every 100 hours of operation.

Air Filter Cleaning

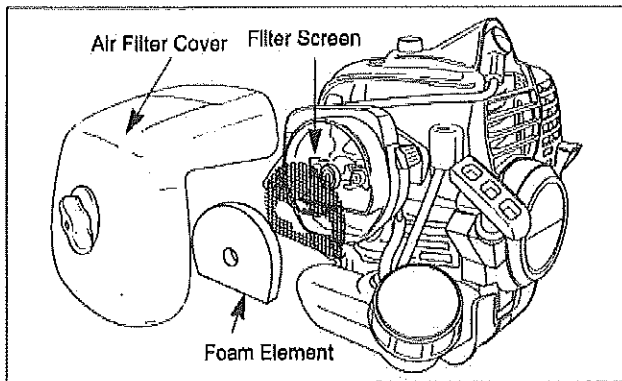

1. Loosen the knob and remove the air filter cover.
2. Remove the foam element and filter screen from the air filter body.
3. Clean the foam element and filter screen with warm, soapy water. Let the screen and element dry completely.
4. Apply a light coat of SAE 30 motor oil to the foam element and squeeze out all excess oil.
5. Reassemble the filter screen and foam element to the air filter body.
6. Reinstall the air filter cover and tighten the knob.

Fuel Filter

Maintenance Interval

The fuel filter should be replaced after every 100 hours of operation.

Fuel filters needing more frequent replacement may indicate debris in fuel tank.

Fuel Filter Replacement

The fuel filter is attached to the end of the fuel pick-up hose inside the fuel tank.

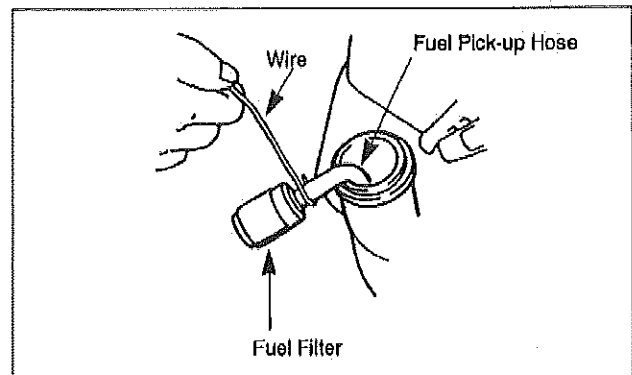

To replace the fuel filter:

1. Make sure the fuel tank is empty.
2. Remove the fuel cap.
3. Using a wire hook, gently pull the fuel filter out through the fuel filler opening. Use caution not to "fishhook" the fuel tube. Replace immediately if punctured!
4. Grasp the fuel hose next to the fuel filter fitting and remove the filter, but do not release the hose.
5. While still holding on to the fuel hose, attach the new fuel filter.
6. Drop the new fuel filter back into the fuel tank.
7. Make sure that the fuel filter is not stuck in a corner of the tank, and that the fuel hose is not doubled over (kinked) before refueling.

Spark Plug

Maintenance Interval

- The spark plug should be removed from the engine and checked after each 25 hours of operation.
- Replace the spark plug after every 100 hours of operation.

Spark Plug Maintenance

1. Twist the high tension lead boot on the spark plug back and forth a couple of times to loosen the boot, then pull the boot off of the spark plug.
2. Remove the spark plug.
3. Clean the electrodes with a stiff brush.

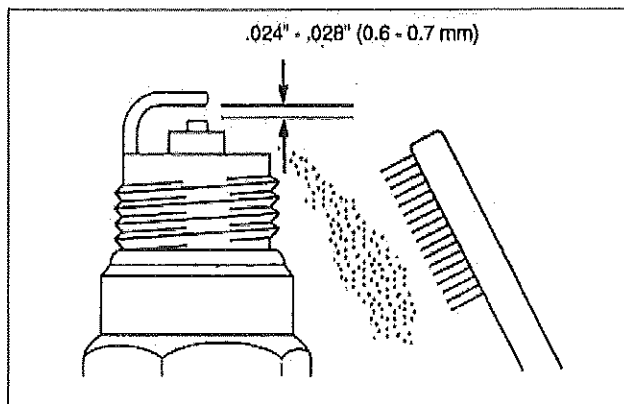

4. Adjust the electrode air gap to .024-.028 in (0.6-0.7 mm).
5. Replace the spark plug if it is oil-fouled, damaged, or if the electrodes are worn down.
6. Do not overtighten the spark plug when installing. The tightening torque is 95-148 in. lbs. (10.7-16.6 N-m).
7. Always use only the specific heat range of spark plug. This is particularly critical with today's low-emission engines. For best results, use the exact replacement.

Cylinder Cooling Fins

Maintenance Interval

The cylinder cooling fins should be cleaned after every 25 hours of operation, or once a week, whichever comes first.

Air must flow freely around and through the cylinder cooling fins to prevent engine overheating. Leaves, grass, dirt and debris buildup on the fins will increase the operating temperature of the engine, which can reduce engine performance and shorten engine life.

Cooling Fin Cleaning

1. With the engine at ambient (room) temperature, loosen the knob and remove the air filter cover.

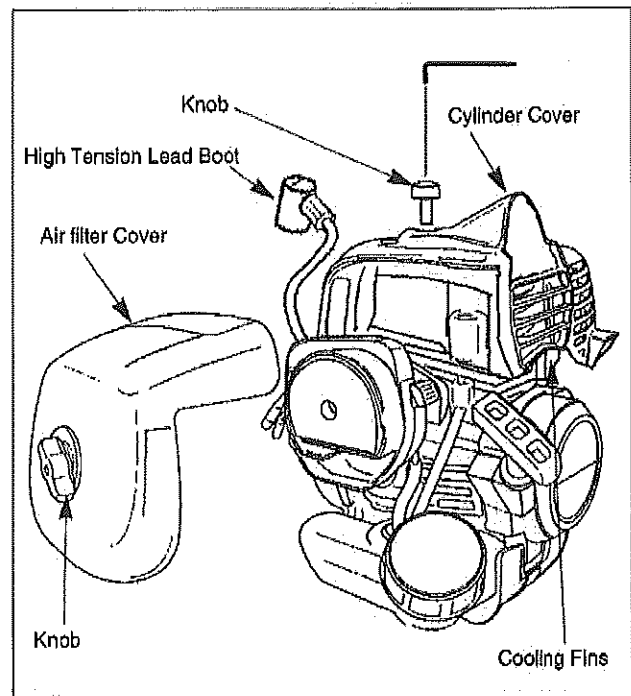

2. Twist the high tension lead boot on the spark plug back and forth a couple of times to loosen the boot, then pull the boot off of the spark plug.
3. Loosen the knob and lift off the cylinder cover.
4. Clean all dirt and debris from the cooling fins and from around the cylinder base.

5. DO NOT overlook cleaning of the cooling air intake area below the crankcase and above the fuel tank! This area must be free of debris and obstruction for the engine to cool properly.
6. Reinstall the fan cover and the filter cover.

Spark Arrester

⚠ WARNING

POTENTIAL HAZARD

- Muffler surface becomes hot when Trimmer/Brushcutter is in operation and remains hot for some time after the engine is shut off.

WHAT CAN HAPPEN

- Contact with hot muffler surfaces could cause a burn.

HOW TO AVOID THE HAZARD

- Make sure the muffler is cool before inspecting and cleaning the spark arrester.

Maintenance Interval

- The spark arrester should be inspected and cleaned after every 25 hours of use.
- Replace the screen if it cannot be thoroughly cleaned, or if it is damaged.

Spark Arrester Maintenance

1. With the engine at ambient (room) temperature, loosen the knob and remove the air filter cover.
2. Twist the high tension lead boot on the spark plug back and forth a couple of times to loosen the boot, then pull the boot off of the spark plug.

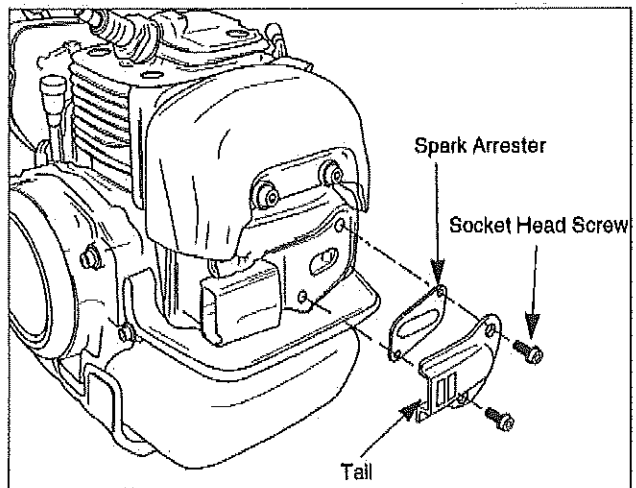

3. Loosen the knob and lift off the cylinder cover.
4. Remove and clean the tail, gasket and spark arrester with a safety solvent and a stiff brush. If any part cannot be thoroughly cleaned, it must be replaced.
5. Reinstall the spark arrester and tail onto the muffler, then reinstall and tighten the two socket head screws.
6. Reinstall the cylinder cover and the air filter cover.

Exhaust Muffler

Maintenance Interval

The muffler should be inspected and cleaned after each 100 hours of use.

Muffler Maintenance

1. With the engine at ambient (room) temperature, loosen the knob and remove the air cleaner cover.
2. Twist the high tension lead boot on the spark plug back and forth a couple of times to loosen the boot, then pull the boot off of the spark plug.
3. Loosen the knob and lift off the cylinder cover.
4. Remove the spark arrester (see spark arrester maintenance), Clean the muffler with a stiff brush.

IMPORTANT: Don't use solvent for cleaning inside of muffler, because of the catalytic converter in muffler.

Be careful not to allow any dirt or debris to fall into the exhaust port, as this can cause engine damage.

5. Reinstall the spark arrester and tail onto muffler, then reinstall and tighten the two socket head screws.
6. Reinstall the cylinder cover and the air filter cover.

Gearcase

Maintenance Interval

The gearcase should be checked for lubrication after each 30 hours of use.

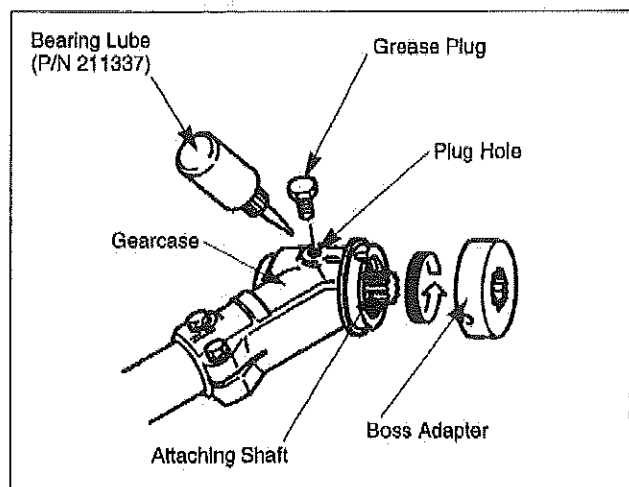

Gearcase Lubrication

Remove the cutting attachment and the boss adapter. Clean any dirt and debris from the area between the boss adapter and the gearcase. Remove the grease plug from the side of the gearcase.

While rotating the attaching shaft, inject lithium-base bearing lube (P/N 211337) through the plug hole until the gearcase is full. Reinstall the boss adapter and grease plug.

General Cleaning and Tightening

WARNING

POTENTIAL HAZARD

- When engine is running, cutting head is rotating and other parts are moving.

WHAT CAN HAPPEN

- Contact with rotating cutting head or other moving parts could cause serious personal injury or death.

HOW TO AVOID THE HAZARD

- Always turn off your Trimmer/Brushcutter before you clean or perform any maintenance on it.

The Maruyama Trimmer/Brushcutter will provide maximum performance for many, many hours if it is maintained properly. Good maintenance includes regular checking of all fasteners for correct tightness, and cleaning the entire machine.

Blade Sharpening

IMPORTANT: Replace any blade that is worn, warped, cracked or otherwise damaged in any way.

IMPORTANT: Sharpen every tooth evenly so the blade rotates smoothly. If you sharpen a blade with a grinder, do not overheat the blade, and do not quench a hot blade in water to cool it. Never leave a sharp radius or groove when grinding or filing.

Four-tooth Blade

Sharpen with a single-cut flat file.

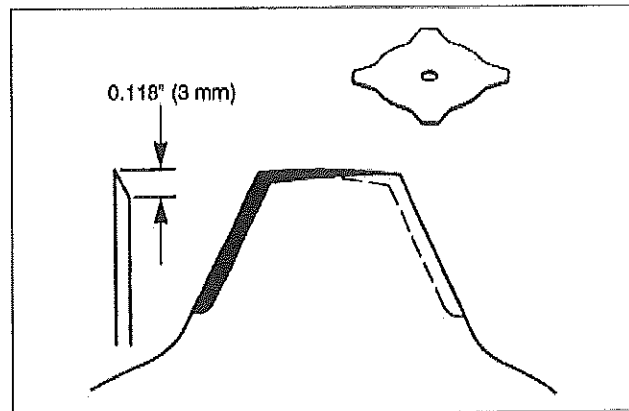

Eight-tooth Blade

Sharpen with a single-cut flat file and a round file.

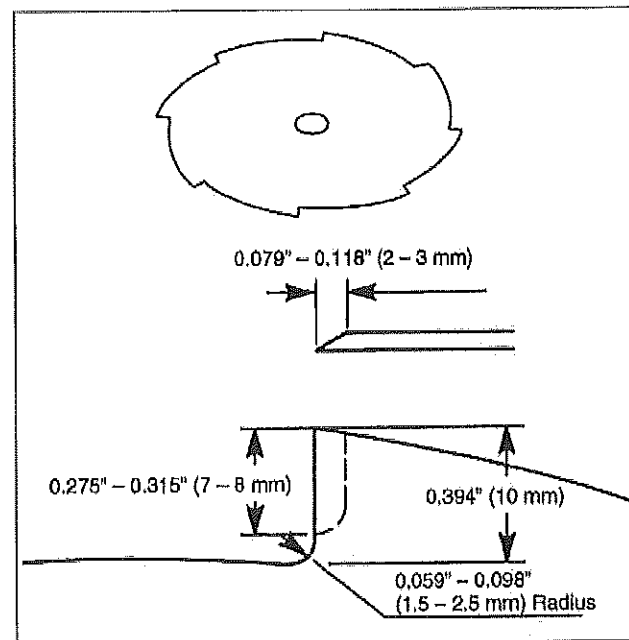

80-tooth Blade

Sharpen with a single-cut flat file and a round file.

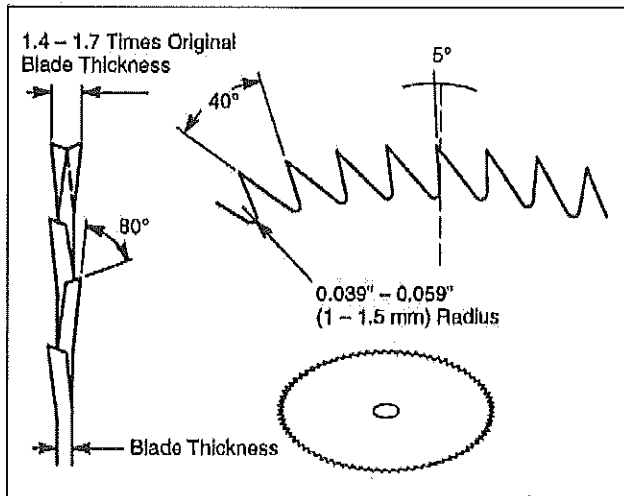

Storage

For long term storage of the Trimmer/Brushcutter:

1. Empty the fuel tank into a suitable fuel storage container.
2. Pump the primer bulb on the carburetor until all fuel is discharged through the clear fuel return hose.
3. Run the engine to remove any fuel that may remain in the carburetor.
4. Perform all regular maintenance procedures and any needed repairs.
5. Remove the spark plug and squirt a very small amount of oil into the cylinder.

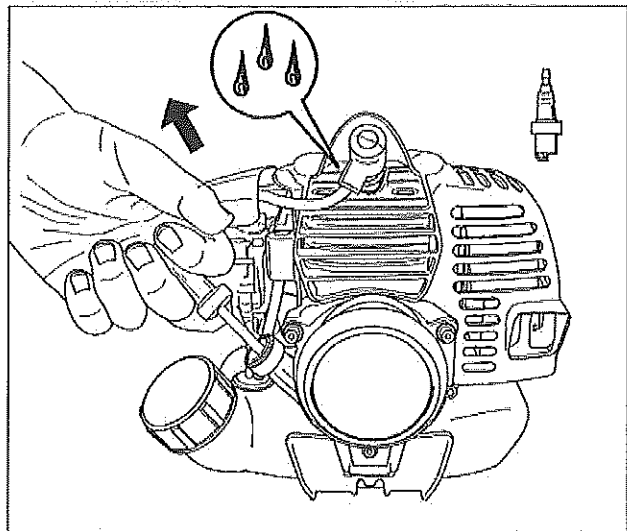

⚠ CAUTION

POTENTIAL HAZARD

- Oil may squirt out of the spark plug opening when you pull the starter grip.

WHAT CAN HAPPEN

- Oil can cause eye injuries.

HOW TO AVOID THE HAZARD

- Protect your eyes and keep your face away from the spark plug opening.
6. Pull the starter grip once.
 7. Slowly pull the starter grip to bring the piston to the top of the cylinder (TDC).
 8. Reinstall the spark plug.
 9. Store the Trimmer/Brushcutter in a dry place away from excessive heat, sparks or open flame.

Troubleshooting

Problem	Cause	Action
Engine Will Not Start	STOP switch set to off position Empty fuel tank Primer bulb wasn't pushed enough Engine flooded	Move switch to on position Fill fuel tank Press primer bulb until fuel flows through fuel return line Use warm engine starting procedure
Engine Will Not Idle	Idle speed set incorrectly	Set idle speed
Engine Lacks Power or Stalls When Cutting	Throttle wire has come loose Dirty air filter Clogged spark arrester or exhaust port.	Tighten throttle wire Clean or replace air filter Clean spark arrester or exhaust port.

If further assistance is required, contact your local authorized Maruyama service dealer.

Maintenance Period

Maintenance	Daily	Every 20 hours	Every 50 hours	Every 100 hours
Check and replenish fuel	●			
Check for fuel leakage	●			
Check bolts, nuts and screws for tightness or missing	●			
Check engine idle speed adjustment	●			
■ Clean air filter element		●		
Tighten bolts and nuts			●	
Clean spark plug and adjust electrode gap			●	
■ Remove dust and dirt from cylinder fins			●	
● Remove carbon deposits in exhaust port			●	
● Clean spark arrester			●	
Replace fuel filter				●
● Remove carbon deposits on piston head and combustion chamber				●
● Remove carbon deposits in transfer ports				●
Replace fuel tube, fuel tank cap gasket	It is recommended to replace every 3 years			

●: Service to be performed by an authorized Maruyama engine dealer.

■: Service more frequently under dusty conditions.

NOTE:

The service intervals indicated are to be used as a guide.

Service to be performed more frequently as necessary depending on operating condition.

Use Maruyama standard 50:1 two-cycle engine oil.

Specifications

	B23L	B27L Turbo	B30L	B30L TURBO
Weight※1(lbs)	11.8	12.4	11.8	12.1
	(5.4 Kg)	(5.6 Kg)	(5.4 Kg)	(5.5 Kg)
Engine Displacement (cm ³)	22.5	25.4	30.1	30.1
Anti Vibration	Dual Isolation - grip and engine mount			
Carburetor	Walbro Diaphragm Type			
Ignition System	Solid State			
Fuel Tank Capacity (qts)	0.53 qts. (0.5 ℓ)	0.63 qts. (0.6 ℓ)	0.63 qts. (0.6 ℓ)	0.63 qts. (0.6 ℓ)
Gas to Oil Ratio	50:1			
Spark Plug	NGK BPM8Y			
Spark Plug Gap (in)	.024 -.028 (0.6 - 0.7 mm)			
EPA and CARB Approved	Phase 3, Tier 3			

	B23	BC2621H	B30
Weight※1(lbs)	12.9	13.1	13.1
	(5.9 Kg)	(6.0 Kg)	(5.9 Kg)
Engine Displacement (cm ³)	22.5	25.4	30.1
Anti Vibration	Engine mount		
Carburetor	Walbro Diaphragm Type		
Ignition System	Solid State		
Fuel Tank Capacity (qts)	0.53 (0.5 ℓ)	0.63 (0.6 ℓ)	0.63 (0.6 ℓ)
Gas to Oil Ratio	50:1		
Spark Plug	NGK BPM8Y		
Spark Plug Gap (in)	.024 -.028 (0.6 - 0.7 mm)		
EPA and CARB Approved	Phase 3, Tier 3		

Emission durability of 300 hours.

※1. Dry weight without Cutting head and strap.



Maruyama U.S., Inc.
3570 Shelby Lane
Denton, TX 76207
Ph: 940.383.7400 / Fax 940-383-7466

www.maruyama.com

3/15/2012.v1